

Thompson Scale Company

Model 4693

Heavy-Duty In-Motion Checkweigher Operation and Maintenance Manual

Version 15.3

Revised December 2011

Thompson Scale Company • 2758 Bingle Rd. • Houston, Texas 77055
Phone 713/932-9071 • Fax 713/932-9379 • Web Site www.thompsonscales.com

INDEX

Important Installation Information	1
1.1 Electrical Requirements & Wiring Methods	1
1.2 Input and Output Connections	2
1.2.1 110 VAC I/O Card	2
1.2.2 24 VDC I/O Card	2
1.3 System Battery for Time/Date Clock	3
1.4 Environmental Rating of Equipment	3
1.5 Warning & Caution Statements	4
Checkweigher Installation	5
2.1 Weigh Station Mechanical Installation	5
2.1.1 Installing the Scale Base	5
2.3 Weigh Station Scale Base Electrical Installation	9
2.4 Checkweigher Controller Installation	9
Calibration	13
3.1 About Calibration	13
3.2 Calibration Check	13
3.2.1 Manual Scale Zero Procedure	14
3.3 Calibration Procedure	14
3.4 Calibration Errors	20
3.5 Displaying Audit Trail Informatio	21
3.6 Print Audit Trail Records	22
3.7 Calibration Theory	22
Controller Set Up	25
4.1 Setting Up the Controller	25
4.1.1 Main Menu Item #1: Run Checkweigher Mode	26
4.1.1.1 Menu Quick Keys	27
4.2 Setting Time, Date, and Rejector Settings	29
4.2.1 Setting Current Time	29
4.2.2 Setting Current Date	30
4.2.3 Setting Rejector Times	30
4.2.4 Good Weight Duration Time	32
4.2.5 Set Reject Overweight Limit	32
4.3 Product Recipe Entry & Edit	34
4.3.1 Entering a New Product	35
4.3.2 Editing an Old Product	37
4.3.3 Edit Password	37
4.3.4 Edit Security Level	38
4.3.4.1 No Key Protection	39
4.3.4.2 Key Protection for Calibration	39
4.3.4.3 Key Protection for Recipe Edit	39
4.3.4.4 Key Protection for Both	39
4.3.4.5 Checkweight Screen Lockin	39
4.3.5 Print System Setup	39
4.2 Minimum System Set Up	40

Controller Configuration	41
5.1 Configuration Menu	42
5.1.1 Setting Sample Rat	42
5.1.2 Setting Filter Frequency	42
5.1.3 Setting Number of Filter Samples	42
5.1.4 Setting Max Production Number	43
5.1.5 Set A/D Gain Number	43
5.1.6 Set Decimal Point	43
5.1.7 Display Slopes	43
5.1.8 Get The Next Menu	44
5.2 Secondary Configuration Screen	45
5.2.1 Clear Audit Trail Record	45
5.2.2 Set Remote Port Mode of Operation	45
5.2.3 Set Display Increments	48
5.2.3.1 Setting Display Increments	48
5.2.3.2 Setting Auto Zero	49
5.2.4 Test Routines	51
5.2.4.1 473 I/O Test	51
5.2.4.2 477 I/O Test	52
5.2.4.3 Test Printer/Remote Port	53
5.2.5 Set Language	54
5.2.6 Set Motor Parameters (Sonic 350 Only)	54
5.2.6.1 Set Conveyor Speed	55
5.2.6.2 Set Acceleration	55
5.2.6.3 Set Motor Type	55
5.2.6.4 Initializing The Cool Muscle Motor	55
5.2.6.5 Set Motor Direction	56
5.2.6.6 Set Auxiliary Motor Parameters	56
5.2.6.7 Set Speed in Recipe	56
5.2.7 Configure Reject Outputs	57
5.2.8 Product Load Options	59
5.2.8.1 Load Locally Setting	59
5.2.8.2 Load Via StatPak-PC	59
5.2.9 Batch Report Enable/Disable	60
5.2.10 "P" Set Photo-eye Configuration	60
5.2.10.1 Early Weight Terminate Photo-eye	60
5.2.10.2 Empty Package Detection	61
5.2.10.3 Conveyor Jam Condition	61
5.2.10.4 High-Rate Photo-eyes	62
5.2.10.5 Detecting Packages Too Close Together	62
5.2.10.6 Photo-eye Response Type	64
5.2.10.7 Photo-eye Response Time	64
5.2.11 "R" Enable or Disable Reject Confirmation	64
5.2.12 "T" Trend Alarm or Overweight Alarm Output	65
5.2.13 "A" Averaging Checkweight Function	68
5.2.14 "F" Weight Feedback Function	70
5.2.15 "N" Next Menu	72
5.3 Third-Level Configuration Screen	72
5.3.1 Set Checkweigher Mode Of Operation	73
5.3.1.1 Normal Checkweigher Mode	73
5.3.1.2 Tandem Checkweigher Mode	73

5.3.1.3 Dual Summation Mode	73
5.3.2 Pacing Logic Photoeye Settings	74
5.3.3 Enable Anybus Communication	75
5.3.4 Setup 477 Transmission	75
Trouble Shooting	79
6.1 Mechanical	79
6.1.1 Weigh Station Conveyor	79
6.1.2 Weigh Station Scale	80
6.1.2.1 Static Scale Stability Test	80
6.1.2.2 Dynamic Scale Stability Test	80
6.1.2.3 Scale Corner Shift Test	81
6.2 Electrical Troubleshooting	81
6.2.1 #470 CPU Card	82
6.2.2 #471 Bus Board	83
6.2.3 #472 Power Supply	83
6.2.4 #473 Output Card	83
6.2.4.1 #573 Input/Output Card	83
6.2.5 #474 Scale Digitizer Card	83
6.2.6 #476 Interface Board	84
6.2.7 #477 Traffic Control Card	84
6.3 Troubleshooting Guide	84
6.3.1 Controller display shows meaningless data or no data	84
6.3.1.1 Display is black or characters not visible	85
6.3.2 Front panel keyboard not working properly	85
6.3.3 Improper rejector operation	85
6.3.4 Remote Zone Light Display not operating properly	85
6.3.5 Erratic or incorrect weighments	86
6.3.6 Failure of controller to zero scale	87
6.3.7 Statistical Package does not print reports	87
6.3.8 One Last Hint	87
Weigh Station Conveyor & Scale	89
7.1 Weigh Station Conveyor	89
7.1.1 Proper Conveyor Installation	89
7.1.1.1 Conveyor Speed Considerations	89
7.1.1.2 Weigh Station Conveyor and Scale Stability	89
7.1.2 Weigh Station Conveyor Adjustments & Maintenance	90
7.1.2.1 Conveyor Belt Tension Adjustment	90
7.1.2.2 Conveyor Pulley Alignment	90
7.1.2.3 Lubrication Schedule	90
7.1.2.4 Head and Tail Pulley Maintenance	91
7.2 Weigh Station Scale Base	91
7.2.1 Changing the Load Cell	92
7.2.2 Weigh Station Scale Corner Corrections	94
7.2.3 Scale Base Lid Adjustment	95

Checkweigher Features	97
8.1 Features Included with Checkweigher	97
8.1.1 Checkweigher Run Screen Statistics	97
8.1.2 Weight Zone Outputs	97
8.1.3 Reject Outputs	98
8.1.4 Remote Serial Port	99
8.1.4.1 Universal Remote Digital Display	99
8.1.5 Trend Alarm & Reject Overweight Alarm	99
8.1.5.1 Reject Overweight Alarm	100
8.1.6 Digital Security Lock	100
8.2 Hardware & Firmware Purchase Options	100
8.2.1 Closed-Loop Feedback	100
8.2.1.1 Counter Feedback Loop	101
8.2.1.2 Pulse Feedback	103
8.2.1.3 ASCII Feedback	105
8.2.1.4 Turn Feedback Off	105
8.2.1.5 Set Pulse Feedback Weight	105
8.2.1.6 Include Rejects in Feedback	105
8.2.2 Remote Product Load	106
8.2.3 Ethernet (TCP/IP) Port	106
8.2.3.1 Ethernet IP Port	106
8.2.4 Analog Output Port	106
8.2.5 Reject Devices	106
8.2.5.1 Reject Inhibit Photo-Eye	107
8.2.5.2 Reject Confirmation Photo-eye	107
8.2.5.3 Reject Lane Full Photo-eye	107
8.2.6 Good Weight Output	108
8.2.7 Early Weight Terminate Photo-Eye Options	108
8.2.7.1 Early Weight Terminate Configuration #1 (EWT1)	109
8.2.7.2 Early Weight Terminate Configuration #2 (EWT2)	110
8.2.7.3 Early Weight Terminate Configuration #3 (EWT3)	110
8.3 Data Collection and Production Reporting Options	111
8.3.1 STPR Statistical Production Reporting	111
8.3.1.1 Unit Weight Listings	111
8.3.1.2 Interim Report	112
8.3.1.3 Final Report	112
8.3.1.4 Description of Production Reports	115
8.3.1.5 Theory of Operation	117
8.3.1.6 Optional Remote Report Switch	118
8.3.1.7 What's Included with STPR	118
8.3.1.8 Statistics Data Menu	119
8.3.2 StatPak-PC Data Logging & Reporting Software	121
8.3.2.1 Communicating with StatPak-PC	121
8.3.2.2 Entering Customer Code Information	124
8.3.2.3 Getting Current Customer Code Information	126
8.3.2.4 No Customer For This Run	126
8.3.2.5 Lot Number Entry	126
8.3.2.6 Reviewing Current Material Parameters	126
8.3.2.7 Down-Time Logging Assignment	127
8.3.3 Displayed Production Statistics	131

8.3.3.1 Production Statistics Display	132
8.3.3.2 Remote Statistics “Count” Reset	133
Spare Parts	135
Serial Port Information	137
A.1 #470 CPU Card “REMOTE” Port	137
A.2 STPR Statistical Reporting Package “PRINTER” Port	138
A.2.1 Serial Converter	140
A.3 #477 Full-Duplex Serial Card	142
A.4 Okidata Printer Configuration Information	143
Checkweigher Controller Batch Ticket Print Feature	145
Remote Product Load	149
C.1 477 Card Protocol	149
C.2 Port Connections	150
C.3 Product Load Commands	150
C.3.1 Entering or Editing A Product	152
Tandem 2-Scale In-Line Checkweigher Mode	155
D.1 Configuration for Tandem 2-Scale System	155
D.2 Tandem Checkweigher User Settings	157
D.2.1 Checkweigher Run Screen for Tandem Checkweigher	157
D.2.2 Checkweigher Recipe for Tandem Checkweigher	157
D.2.3 Checkweigher Reject Times for Tandem Checkweigher	157
Ethernet Interfaces	159
E.1 Ethernet TCP/IP	159
E.2 Ethernet IP Introduction	160
E.2.1 Ethernet IP Communications	161
E.2.2 Limits and ranges for recipe parameters	162
E.2.3 Response Codes	163
E.2.4 Input Memory Layout	164
E.2.5 Output Memory Layout	165
E.2.6 Data Output from EIP	166
Typical System Drawings	167

FIGURES

#477 Card Layout	142
Audit Trail Data Display	21
Audit Trail Name Entry	15
Audit Trail Time & Date Screen	15
Auto Zero Settings	50
Auto Zero Time	51
Automatic Span Adjustment Screen	19
Auxiliary Motor Parameters	56
Average Checkweigh Function	68
Batch or Continuous Mode for StatPak-PC	123
Batch Report Enable Screen	146
Batch Report Settings	147
Calibrating Span	18
Calibration Check Display	14
Calibration Main Menu	14
Calibration Test Weight Selection	16
Checkweigh Mode Display	27
Checkweigher Mode Setting	73
Closed-Loop Feed Back Option	71, 101
Configuration Menu	42, 145
Controller Back Panel	11
Controller Back Panel Details	82
Controller Front View	10
Count Feedback Setting #1	102
Count Feedback Setting #2	102
Display Increment Setting	48
Displaying Current Down-Time Data	129
Down-Time Prompt on Main Ckw Screen	128
Edit Security Level	38
Enter Average Wt. Limits	70
Enter/Edit Product Main Menu	34
Entering A New Product	35
Entering Calibration Test Weight	16
Entering Product Weight Parameters	36
Final Calibration Settings	19
Final Zero Settings	18
Good Wt. Duration Setting	32
High Reject Output Configuration	58
Load Cell & Flexure Detail	93
Load Pedestal Shim Installation	95
Main Checkweigher Display	26
Main Ckw Screen with Batch Report Prompt	147
Main Menu	25
Metal Reject Output Configuration	58
Optional Product Listing Report	39
Overweight Alarm Setting #1	66
Overweight Alarm Setting #2	66
Pacing Logic Settings	74
Password Entry Screen	38

Photo-Eye Reject Methods	63
Printer Schematic	139
Product Load From StatPak-PC	124
Product Load Options	59
Product Recipe & Weight Averaging	69
Pulse Feedback Setting #1	104
Pulse Feedback Setting #2	104
Recommended Scale Base Mounting	6
Reject Output Configuration	57
Reject Overweight Error Screen	33
Reject Overweight Limit Entry	33
Reject Signal Timer Settings	32
Remote Port Schematic	137
Remote Port Settings	45
Reviewing Product Setups with StatPak-PC	126
Reviewing The Current Product Setup with StatPak-PC	127
RZDP Light Tower	98
Scale Base Assembly	92
Scale Base Top View	94
Scale Shift Test	81
Secondary Configuration Screen	44, 146
Select Tandem Checkweigher Mode	156
Select Trend/Overweight Alarm	65
Selecting Customer From StatPak-PC	124
Selecting English/Spanish Menus	54
Selecting Material Name From StatPak-PC	125
Selecting Optional Photo-Eyes	60, 156
Selecting Production Data Mode	128
Selecting Production Load Option	122
Serial Card Configuration	75
Setting Acceptable Down-Time Value	131
Setting Acceptable Down-Time Value Screen #2	131
Setting Average Or Mean Value	27
Setting Calibration Zero	17
Setting Date Screen	30
Setting Discard Limits	120
Setting Motion Band	50
Setting Motor Parameters	55
Setting Multi-Stream Remote Mode	46
Setting Resolution	49
Setting Time Screen	29
Setting Trend Alarms	99
Setting Zero Screen	17
Slope Settings	44
Statistics Data Main Menu	119
Summary Report	114
Tandem Checkweigher Display	157
Third Level Configuration Screen	72
Time/Date Main Menu	29
Unit Weight Listing Report	112
Weigh Station Assembly	7

Weight Output Setting #1	67
Weight Output Setting #2	68
Weight Averaging Limits	69

Chapter 1

Important Installation Information



WARNING: THIS EQUIPMENT IS TO BE INSTALLED AND SERVICED BY QUALIFIED SERVICE PERSONNEL ONLY.

Instructions within this manual and attached drawings are to be strictly followed to insure both personnel safety and proper operation of the equipment. Please carefully read this chapter, and chapters 2 & 3 regarding mechanical and electrical installation, and controller configuration before attempting to install or operate this equipment.

1.1 Electrical Requirements & Wiring Methods

The Checkweigher controller requires 110 VAC power from a dedicated branch circuit breaker rated at **15 Amps Max.** This breaker is to be used as the primary means of disconnecting power from the Checkweigher controller when performing maintenance. *Please practice safety when working on or around the Checkweigher equipment.*

The Checkweigher controller does not typically require an isolation or power conditioning transformer. Power from 89 to 130 VAC, 50/60 Hz. is acceptable. Minimum wire gauge for supply wiring is 16 Ga. stranded conductor, provided with an Earth Ground. Solid conductors should not be used.

All wiring routed to or from the Checkweigher controller must be provided in accordance with National Electrical Code requirements to maintain the NEMA 4X (IP67) rating of the control enclosure. Recommended conduit sizes and wire sizes are noted on controller layout drawing, found at the back of this manual.

Voltage supply wiring must be routed per instructions found on the controller layout drawing found at the back of this manual.

The #472 Power supply card located within the Checkweigher controller provides a termination point for supply 110 VAC power and Ground. The “Hot” side of the supply voltage (L1) is terminated on the “L1-IN” terminal on the face of the #472 card. Voltage is internally routed through a fuse located on the #472 card (F4), and the card’s front panel Power On/Off switch. A front panel voltage output terminal (L1-OUT) should be used for powering internal I/O cards within the controller. Fuses for 5 VDC (F1) and +24 VDC (F2) and -24 VDC (F3), which are voltages used internally on the card rack, are also found on this card. Fuse sizes and ratings for the #472 Power Supply card can be found below, and on the schematic drawings at the back of this manual.

Replace each fuse with the same or equal type of fuse, as noted below:

- F1 5 x 20 mm Fuse; 250 Volt rated, 2 Amp, Fast-Acting Glass Fuse
(Spare fuse in upper left corner of #472 card (F7))
- F2 & F3 TE5 Sub-miniature Fuse; 125 Volt rated, 0.315 Amp, Fast-Acting
(Spare fuse on left side of #472 card (F5 & F6))
- F4 3AG Fuse; 250 Volt rated, 1 Amp, Fast-Acting Glass Fuse
(Spare fuse on right side of #472 card (F8))

1.2 Input and Output Connections

The Checkweigher controller can be supplied with either a 110 VAC I/O card (#473) or 24 VDC I/O card with sinking or sourcing inputs and 24 VDC outputs (#573). Each are described below:

1.2.1 110 VAC I/O Card

The Checkweigher controller can be provided with a #473 I/O card, providing eight (8) 110 VAC Inputs and eight (8) 110 VAC solid state outputs. These I/O are described on the interconnection and schematic drawings found at the back of this manual.

Inputs on the #473 card are rated for 110 VAC, maximum 500mA current draw, 50/60 Hz., and are intended for the connection of resistive devices and contact closures from field devices such as limit switch contacts, photo-eye contacts, or push button contacts. Do not connect DC voltages to these inputs.

1.2.2 24 VDC I/O Card

Thompson Scale Co. offers a 24 VDC solid state I/O card. The #573 I/O card differs in appearance from the #473 110 VAC I/O card. The face plate of the #573 is black with white lettering, and clearly states the DC voltage on the face plate.

Some model checkweighers include a 110 VAC to 24 VDC switching power supply module. For models without this power supply, one can be provided at additional cost. The power supply module mounts to the controller back panel, directly below the card cage. 110 VAC power from the L1-OUT and L2 terminals of the #472 power supply card are connected to the source power connection of the switching power supply. The 24 VDC power output from this supply is then connected to the L1 and L2 power connections on the #573 card.

The #573 I/O card can be configured by the connection of source power and the device to each input as either sinking (voltage in reference to ground), or sourcing (voltage in reference to +24 VDC). A truth table on the face plate of the #573 describes interconnection of either sink or source. See the schematic drawings at the back of this manual for more information.

1.3 System Battery for Time/Date Clock

The Checkweigher controller contains a time/date clock for use with the system's calibration audit trail and for calculating production rates and time/date stamps used on production reports. The time/date clock I.C. chip located on the system's #470 CPU card is maintained by a self-charging battery, which is also located on the #470 CPU card. This battery will continue to properly operate the time/date clock chip for a period up to 6 months if AC power is lost to the controller.

The self-charging battery is designed to last for the life of the CPU card, and will never require field replacement. The battery is permanently affixed to the printed circuit card, and under no circumstances should it be removed for testing, repair, or replacement. Contact Thompson Scale Co. for instructions on return of the #470 CPU card in case of battery failure.



CAUTION: Danger of Explosion if battery is incorrectly replaced. Replace only with the same or equivalent type recommended by the manufacturer. Dispose of used batteries according to the manufacturer's instructions.

1.4 Environmental Rating of Equipment

The Checkweigher controller is housed in a NEMA 4X (IP67) rated enclosure. Conduit openings can be placed along the sides and/or bottom of the enclosure and are to be used for routing power, load cell, and I/O wiring to and from the enclosure. Conduit openings for the wall mount style enclosure may be made in the enclosure, in accordance with specifications shown on the controller layout drawing at the back of this manual. The pedestal style enclosure contains five (5) ½" conduit holes on each side of the enclosure. Additional holes can be added anywhere along the sides, as required.

Properly rated conduit connectors and installation practices must be used to maintain the environmental rating of the enclosure.

Conveyor motors and their degree of protection are described on the general layout and/or conveyor layout drawings included at the back of this manual.

The recommended operating temperature for the Checkweigher controller is -10° to +40° C

1.5 Warning & Caution Statements



WARNING: POSSIBLE UNINTENDED REJECT ACTUATION CAN OCCUR:

The Checkweigher controller may automatically generate a weighment if the weigh station conveyor or scale is manually depressed. This may generate a reject signal, which in turn may unexpectedly actuate or operate a reject mechanism.

The Checkweigher controller should be placed into either the CAL CHECK menu or turned OFF before performing maintenance on or around the Checkweigher weigh station conveyor. Reject devices should be disabled and locked out before attempting to work on the Checkweigher or reject device.



CAUTION: SENSITIVE WEIGH STATION COMPONENTS

The Checkweigher is a precision weighing instrument. Standing on, crossing, side loading, or overloading the weigh station conveyor **WILL** damage the electronic load cell, rendering the system inoperable.

The Checkweigher weigh station conveyor must be installed in accordance with the installation instructions found in the Chapter 2, and general layout or conveyor specific drawings found at the back of this manual

The weigh station conveyor must be protected from overload conditions, such as impact from fork lifts, dropped heavy loads (packages dropped from a height of more than 3"), and personnel standing, walking on, or crossing this conveyor.



WARNING: WEIGH STATION CONVEYOR MAY START AND STOP UNEXPECTEDLY. FOLLOW PROPER LOCK-OUT PROCEDURES BEFORE WORKING ON THIS EQUIPMENT

Thompson Scale strongly urges that proper lock-out procedures are used to disable conveyor operation prior working on or around the equipment.

Chapter 2

Checkweigher Installation

2.1 Weigh Station Mechanical Installation

The 4693 Heavy-Duty Checkweigher system is comprised of three basic components: Weigh station scale base, Weigh station conveyor, and Checkweigher controller. This section will cover the physical installation of these components into your production line. Information on electrical wiring of these components are detailed on the interconnection and schematic drawings found at the back of this manual.

There are several important items to consider before beginning installation of the weigh station. For the highest possible accuracy and best system performance, it is important to provide a smooth transition of the package on to and off of the weigh station conveyor. The weigh station conveyor should be:

Same height as the in and out feed conveyors

Running at same speed as in feed and out feed conveyors

Close as possible to in and out feed conveyors pulleys, without conveyor frames or pulleys touching.

Free from any restrictions from cables, conduits, straps, etc. See Electrical Installation in section 2.2 below.

2.1.1 Installing the Scale Base

The scale base provided with your system is a flexure style scale containing a S-type load cell and flexure plates mounted into a rigid base unit. This base also contains drilled and tapped mounting holes for installation. **See Chapter 7** for more information on this scale.

Follow the directions below for proper installation of the scale base:

1. The scale base should be mounted to a rigid and stable surface such as a grouted and level floor or support structure. All four corners of the scale should lay flat against the surface. If one corner rocks or doesn't lie flat, place shims beneath that corner until the scale is stable and does not rock. See the diagram below:

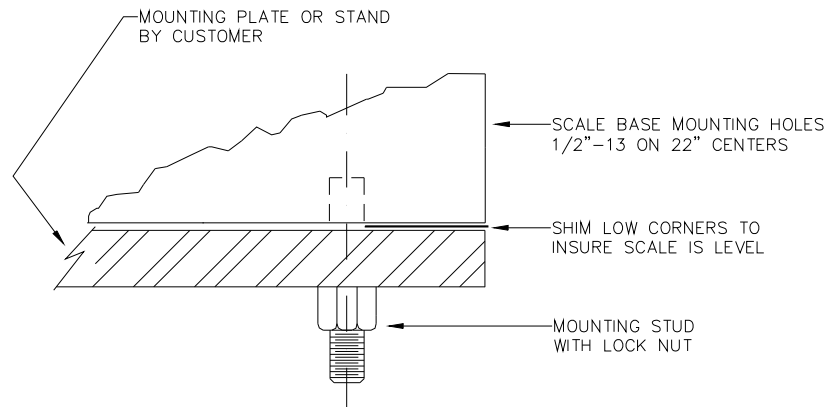

Scale Mounting Recommendation

2. Once the scale base is in place, mounting bolts should be installed. *It is critically important NOT to torque or skew the scale base frame when tightening the mounting bolts.* Again, shim corners as required.
3. Note the two shipping straps attached between the base framework and the load spider on either side of the load cell. These straps are painted Orange and are held in place with a screw at the bottom of the strap. Remove the screw and shipping strap completely.
4. Now that the scale base is properly installed, pass the load cell cable thru the access hole in the side of the scale. Place the scale lid on top of the scale base unit. This lid may be placed in any orientation and does not require fasteners to secure in place.
5. Using moving straps placed around the weigh station conveyor, or other safe means, and gently lower the conveyor onto the scale base. It is important to use caution in placement of this conveyor. **DO NOT DROP OR FORCIBLY SLIDE THE CONVEYOR ON THE SCALE.** This can cause serious damage to the scale base, load cell and/or scale base flexures!

NOTE: The weigh station conveyor should be oriented such that the driven roll (roll with adjustable take-up bearings) should be at the IN-FEED END of the conveyor line. That is, the drive pulley should be pulling the belt and not pushing it.

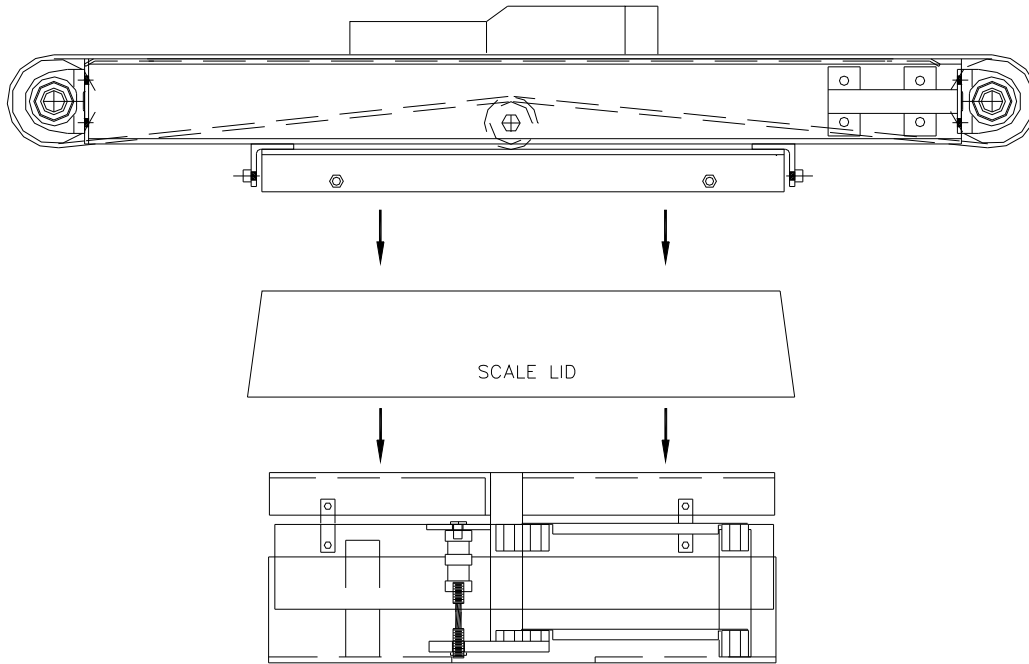

Scale & Conveyor Assembly

6. The weigh station conveyor can now be gently lifted and shifted for proper alignment with up and down stream conveyors. Once this is completed, the nesting frame retaining bolts on the underside of the conveyor can be loosened and run in until they touch the scale base lid. Tighten the retaining bolt jam nuts to secure the bolts in place.

**THESE BOLTS SHOULD BE ADJUSTED TO HAND TIGHT ONLY.
DO NOT OVER TIGHTEN THESE BOLTS!**

7. Using a bubble level, check and confirm that the weigh station conveyor is level and plumb, and that the in-feed and out-feed conveyors are level to the weigh station conveyors. Product should make a smooth transition onto and off of the weigh station conveyor.
8. Press down on each corner of the weigh station conveyor to confirm it is solid and does not rock or bounce. If a corner of the conveyor does rock, then remove conveyor and check the scale base and lid to make sure each item is secure and level. A rocking or unstable weigh station conveyor will NOT produce reliable or accurate weights.

2.2 Weigh Station Conveyor Electrical Installation

Now that the mechanical installation is complete, the conveyor motor and load cell must be connected to their respective devices.

Weigh station conveyor motor should be wired with a 4 conductor 14 Ga. SJO style cord, or flexible liquid tight conduit. This will provide the greatest flexibility for the scale. Since a scale device is basically a spring, it is important not to restrict the movement or response of that spring. Improperly installed motor or photo-eye cabling attached to the weigh station will cause erratic response of the scale to an applied load.

SJO or Seal-Tite should be installed with a minimum of 360 degree loop, as noted in the figure below:

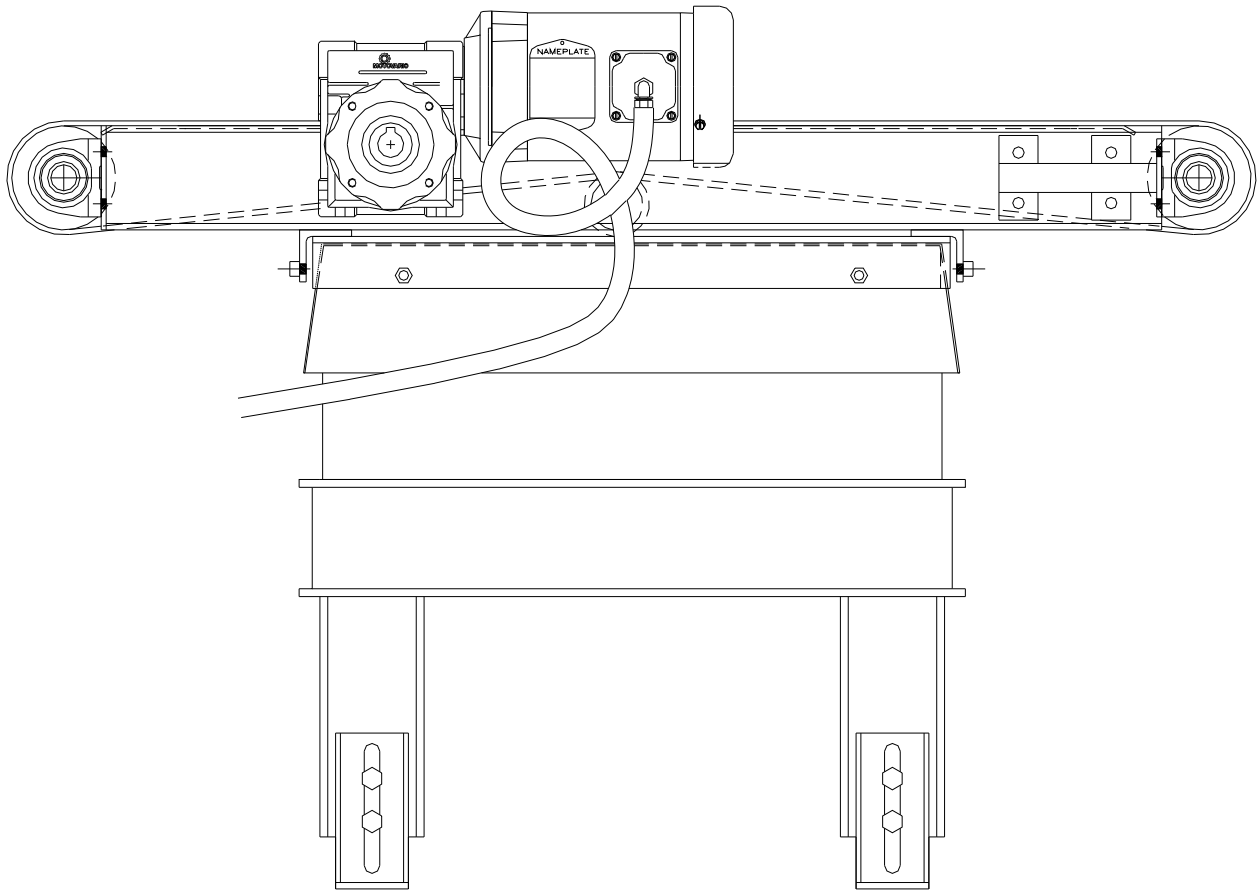

Other devices, such as grounding straps, photo-eye cables or other sensors, print heads, etc. can be added to the scale conveyor, as long as the same precaution is taken regarding the cabling. The goal when wiring the motor or adding sensors is to provide a free-moving and responsive scale.

Once all wiring has been attached to the scale conveyor, or new wiring is added, it is recommended that a scale corner test is conducted. See instructions for this corner test in Chapter 6.

2.3 Weigh Station Scale Base Electrical Installation

The weigh station scale base is equipped with an electronic load cell with a four (4) conductor foil wrapped, shielded cable with an un-insulated ground drain wire potted into the body of the load cell. This cable is approximately 20 feet long and is covered by an oil and chemical resistant jacket.

The load cell cable should be run in dedicated conduit directly to the Checkweigher controller whenever possible. If it is necessary to extend this cable beyond 20 feet, a splicing kit specifically designed for load cell cables should be used. Use of standard screw or barrier terminals, or wire nuts is not recommended since terminals and/or conductors at these terminations can oxidize or corrode over a period of time causing variances in resistance of the load cell output, ultimately affecting system accuracy.

Please consult local scale distributors or call Thompson Scale Co. for information regarding load cell splicing kits.

Load cell cables should **NEVER** be run in conduit containing other wiring, or run open and unprotected over a long distance or across a floor or walkway. Either of these approaches present the possibility of mechanical damage to the load cell cable and its conductors. Shorting of the load cell cable will damage the load cell and/or the #474 Scale Digitizer Card.

A permanent and effective grounding means should be employed for the scale base. This can be accomplished by attaching a grounding bus, such as size 0 wire or bare grounding cable directly to the scale base unit (not the scale lid) and/or the scale base support structure.

Details on interconnection of the load cell cable to the Checkweigher controller are detailed in the interconnection and schematic drawings at the back of this manual.

2.4 Checkweigher Controller Installation



The Model 4693 Checkweigher controller is to be installed by only qualified technical personnel familiar with local and national wiring code requirements.

Installation by other than qualified personnel may possibly damage equipment or injure personnel or operators.

Use of electrical fittings or hardware other than rated for use in a NEMA 4X or IP66 environment will degrade the intended protection provided by the electrical control enclosure. Refer to the controller detail drawing at the back of this manual for more information on proper wiring methods, conduit sizes, fittings, and proper wire gauge.

The Checkweigher controller requires the use of an external disconnect source, such as a breaker or fused disconnected rated at 15 Amps. This disconnect should be used to remove power from the Checkweigher controller before opening the enclosure. Failure to remove power before opening enclosure exposes personnel to energized components and terminals. Contact with these live circuits may result in injury.

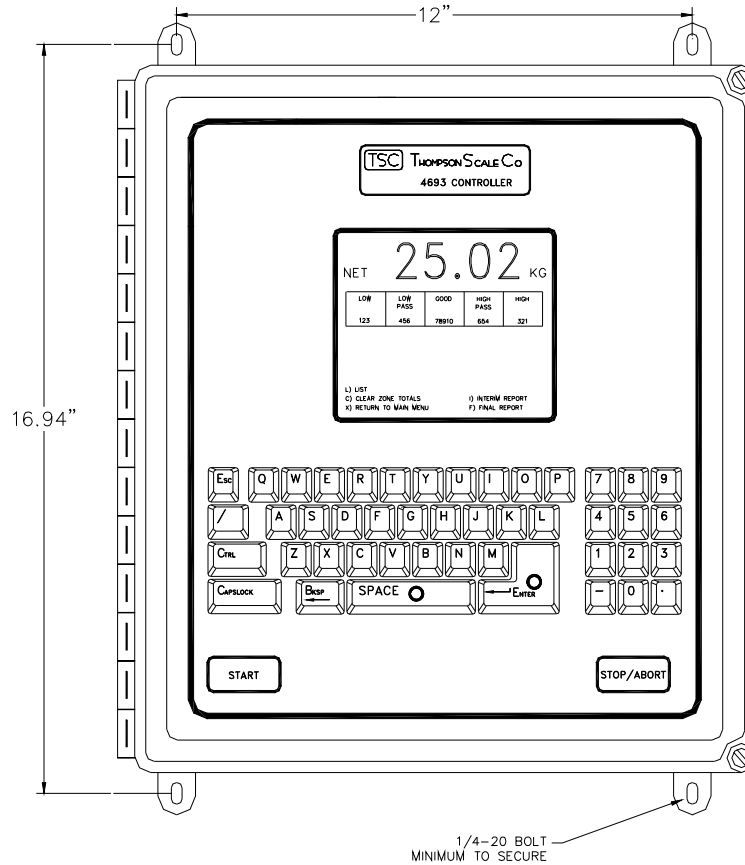

The Checkweigher controller cabinet is a Nema 4X rated fiberglass or optional Stainless Steel enclosure. Overall Size is 16" x 14" x 8" in depth, with S.S. hinge and cover screws. The front panel of the controller is overlaid with a membrane switch panel which also contains a 4.3" x 5" scratch resistant display window. Mounting feet are provided for wall or plate mounting.

The Checkweigher controller and front panel overlay are designed for use in hostile, corrosive, or wash down environments. The enclosure must be kept tightly closed to maintain integrity, and should only be opened for trouble shooting purposes. It is also recommended that the controller be placed on a relatively vibration free mount. This will of course improve visibility of the controller display, and will also assist in prevention of loosening components or terminations within the system.

All electrical interconnections should be made through conduit hubs provided on the enclosure, and/or through any additional conduit hubs as noted on the controller detail drawing at the back of this manual. It is extremely important to properly utilize these conduit hubs to minimize or otherwise eliminate the possibility of leaking or dripping fluids or dust particles from entering the enclosure.

The Checkweigher controller should be placed in a location near the weigh station conveyor and scale to facilitate calibration and trouble shooting as required. Ultimately, this would be within 20 feet of the weigh station scale, taking into account the total number of feet contained in the load cell cable's conduit run. Locating the controller within this 20 foot radius will eliminate the need for splicing the load cell cable, which eliminates the possibility of problems with faulty or corroding splices or terminals in the future.

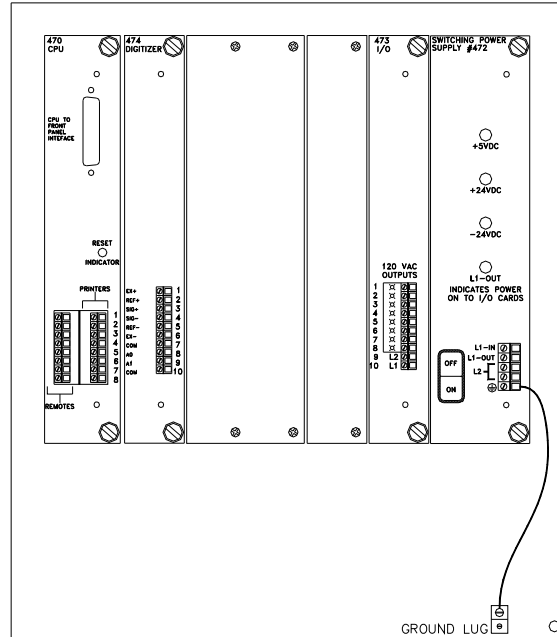

CONTROLLER BACK PANEL LAYOUT DETAILS

Internally, the Checkweigher controller houses a unitized card rack, which contains all of the necessary printed circuit boards to operate the Checkweigher and any accessories. At the far right end of the card rack, is the #472 Power Supply Card. Terminals are provided on the face of this card for connection of 110 VAC supply power to the controller. See the interconnection and schematic drawings at the back of this manual. The #472 card also contains fusing for protection of in-coming supply power, 24 VDC power and 5 VDC power supplied to the card rack. A "Power On/Off" switch is also supplied to facilitate trouble shooting and other circumstances that may require disconnecting power to other cards within the system. It is recommended that an external switch and/or branch circuit breaker is used as the primary disconnect means for this equipment. Please refer to Chapter 1 and drawings at the back of this manual for more information.



**PROPER GROUNDING IS REQUIRED!
NOT INSTALLING A GOOD EARTH GROUND
CAN LEAD TO DAMAGE OF EQUIPMENT
OR POSSIBLE INJURY TO PERSONNEL.**

A ground lug is provided on the checkweigher controller's back panel. A ground lead from this lug to the ground terminal on the #472 Power Supply's terminal block is pre-wired at the factory. Earth Ground from the in-coming supply power should be connected directly to the ground lug.

Chapter 3

Calibration

Entering into Main Menu Item #3 allows access to the calibration procedure for this system. While in the **Calibrate Scale** menu all checkweigh functions are disabled. Checkweigh functions are automatically enabled immediately upon exiting from this screen.

3.1 About Calibration

The Checkweigher controller does not require the adjustment of potentiometers to set Zero or Span for the scale. All adjustments are performed by internal digital potentiometers and gain amplifier adjustments. Each sub-menu within calibration steps the operator through the entire process, displaying important calibration data as it proceeds.

The Checkweigher is equipped with password protection (can be disabled) for both calibration and product recipe entry. Information regarding entering or editing a password is contained in Chapter 4. Calibration also contains entry of data for the audit trail. Audit trail information cannot be by-passed and must be entered upon each calibration of the system. This information is a type of electronic "seal" and allows for tracking of when calibration was done, and by whom.

Calibration should be performed with a known certified test weight whenever possible. Use of other weights or filled product containers often leads to inaccurate calibration, which ultimately affects system accuracies. The system can be calibrated in Pounds or Kilograms, Ounces or Grams, but does not require calibration in more than one conversion.

If calibrating in pounds or kilograms, weight conversions used in product recipes can be in either pounds or kilograms. However, if calibrating in ounces, recipes must be set in ounces. If calibrating in grams, recipes must be set in grams. **CURRENT PRODUCT RECIPE MUST BE SET TO THE PROPER UNIT CONVERSION BEFORE CALIBRATING IN THE SAME CONVERSION.**

The entire calibration procedure takes approximately 2 to 3 minutes to complete, and should be done on a regular schedule. In applications where product accumulation on the weigh station is a factor, the conveyor and scale should be completely cleared of all product to insure as accurate as possible calibration. We recommend calibration on a monthly basis, with calibration checks performed on either a shift or daily basis, or whenever the weigh station has been subjected to cleaning or maintenance.

3.2 Calibration Check

The Checkweigher controller has been programmed with a means for the operator to check calibration and scale accuracy without the need to enter or execute calibration. Select Main Menu Item #2, Calibration Check. The display shows current live Gross weight in the current conversion (lbs., kg., etc.) as shown in the following figure.

To facilitate a stable displayed weight, the display is updated at a slow rate of approximately 3 times per second. A known test weight value can be placed onto the weigh station conveyor, and its Gross weight will be displayed. If the operator decides that the weight value displayed is out of tolerance, a complete calibration should be performed.

3.2.1 Manual Scale Zero Procedure

In calibration check mode, raw weight is shown, which may include product accumulated on the weigh station conveyor and any drift due to wind currents or vibration. The operator can zero the display by pressing the “Z” key on the keyboard. **This will zero the displayed weight and set a new operating zero for the scale.** The display will show a 0.00 reading.

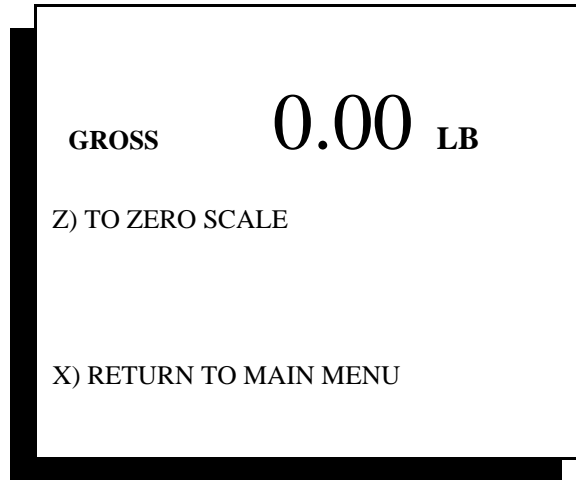

Calibrate Check

3.3 Calibration Procedure

Calibration consists of several screens that prompt the operator to clear the weigh station and apply the test weight, with the controller automatically setting zero and span. Following are the sub-menus in order of occurrence for calibration. Each menu screen is followed by a brief description of each step.

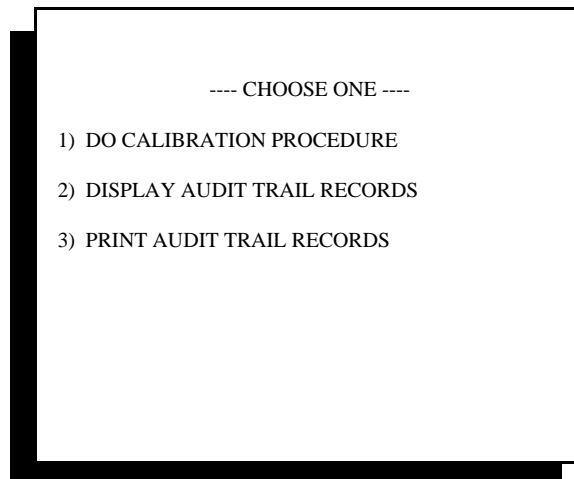

Calibrate Sub-Menu 1

This screen appears whenever Main Menu item #3 is selected. Each sub-menu will be described in order below. Selecting Item #1 will take the operator through calibration. Calibration's first menu is shown below.

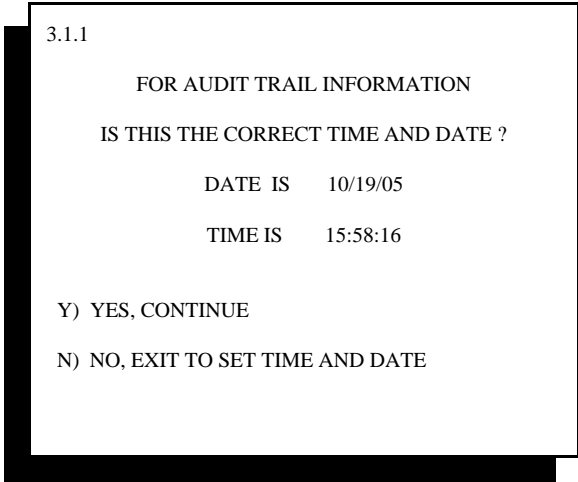

Audit Time and Date

Sub-menu box 3.1.1 above, displays the current time and date used as part of the audit trail information. If time and date are not correct, exit from this menu and go to the Enter/Edit Time, Date, Rejector Times Menu. If time and date are correct, proceed by pressing "Y" as prompted.

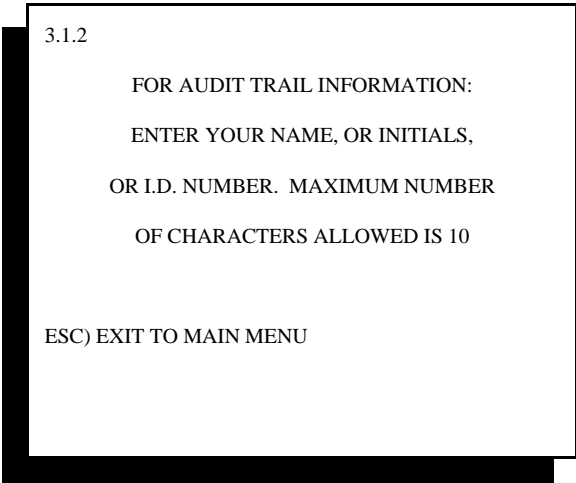

Audit Trail I.D.

The menu shown above asks for entry of the person's name or initials, or an I.D. number that will be referenced in the audit trail stored in memory. A minimum of 1 character, and a maximum of 10 characters must be entered. Entering more than 10 characters will display on the screen, but only the first 10 characters will be stored with the audit trail.

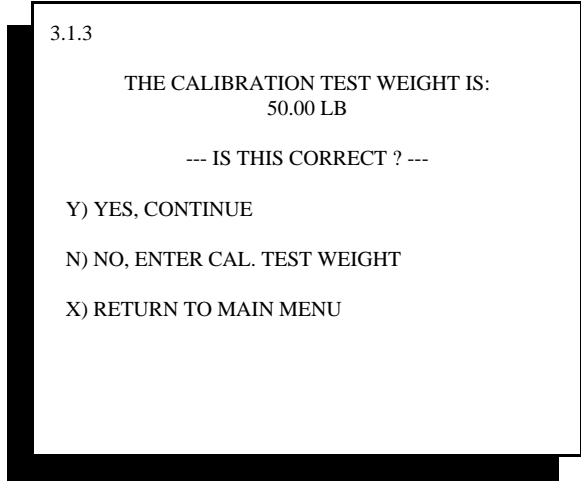

Confirming Test Weight Size

Sub-menu 3.1.3 offers a default test weight setting to be used for calibrating the scale. You have the option to accept this test weight value, or enter a new value which will be retained in memory as the default, or exit back to the main menu.



PLEASE NOTE: CALIBRATION TEST WEIGHT VALUE SHOULD BE EQUAL TO A MINIMUM OF 50% OF THE HEAVIEST PRODUCT RUN ON THE SCALE.

The sub-menu shown below describes the selection for entering a new test weight value. This menu also allows for the selection of a new weight conversion. Please note that selection of ounces and grams is restricted to systems with a full weight capacity of 20 lbs (10 kg) or less. Refer to project system drawings and scale base information to confirm capacity of your scale.

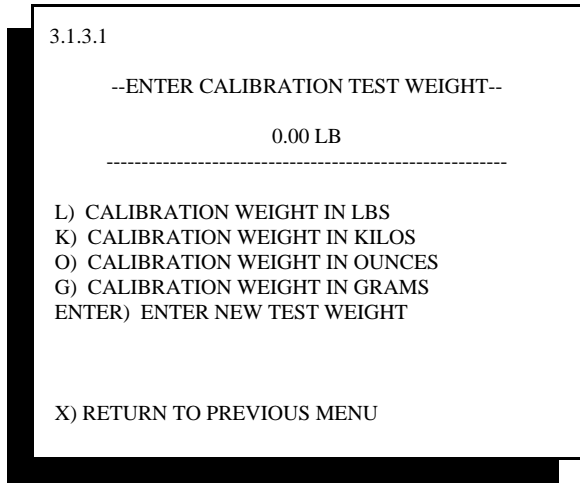

Entering New Cal Weight Value

Once a valid calibration weight has been selected, sub-menu 3.1.4 shown below automatically appears, instructing the operator to clear the weigh station before proceeding.

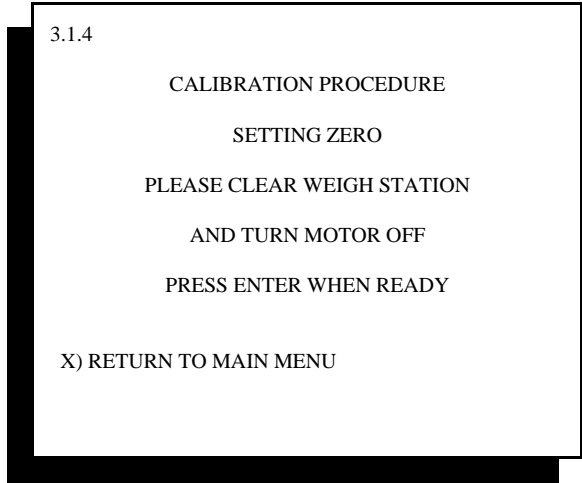

Cal Zero Setting Prompt Screen

Again, the operator is presented with the option to exit from this procedure and return to the main menu without affecting the existing calibration. If the operator presses Enter, the screen advances to menu 3.1.5

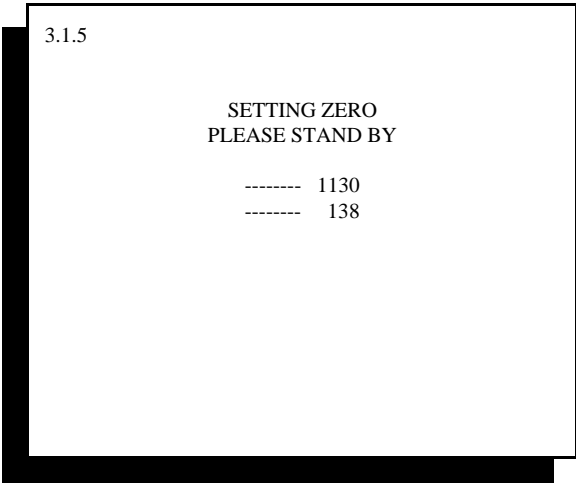

Calibration Zero Adjustment Screen

In setting Zero for this system, the controller displays two values. The top value is a variable adjusted by the digital instrumentation amplifier. This value references a zero operating point, and should change during this step as the second value self-adjusts.

The second value is an internally generated variable corresponding to a digital reference within the #474 Scale Digitizer card, and is used as the Zero reference throughout the rest of the controller's program. If these values do not adjust, or an error is displayed, refer to the Trouble Shooting guide in Chapter 6 of this manual.

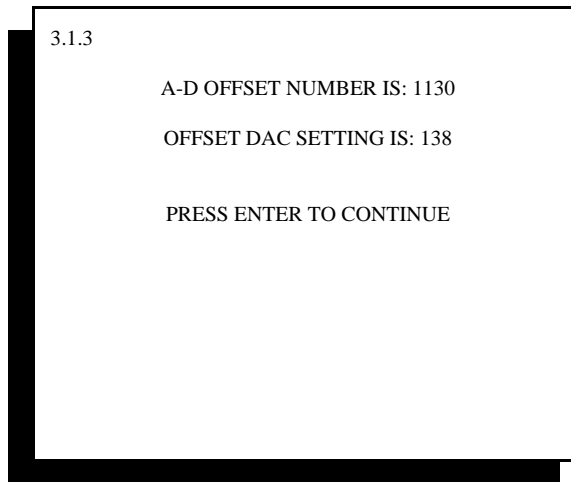

Calibration Zero Adjust Confirmation

Once the Checkweigher controller has automatically adjusted zero, it will display information on the zero setting. This data will vary only slightly calibration to calibration, but will show drastically different numbers if damage to the load cell or Scale Digitizer card occurs. Pressing Enter will bring the operator to the next step in calibration.

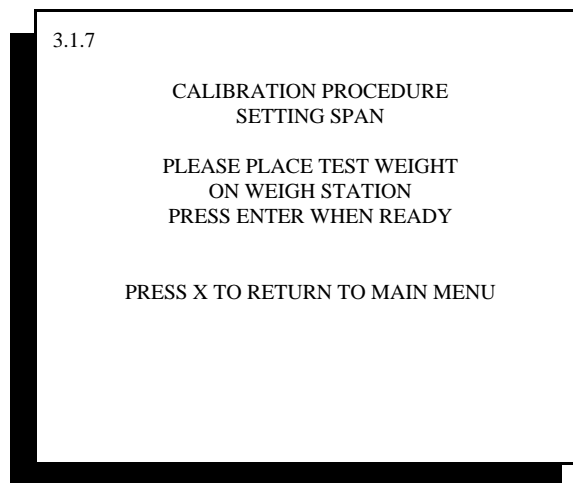

Calibration Span Prompt Screen

At this point, the operator is instructed to place the test weight onto the center of the weigh station conveyor and give the system a moment to settle before pressing "Enter". The controller now automatically adjusts the internal digital potentiometer to achieve the highest possible span ratio as shown in the screen below.

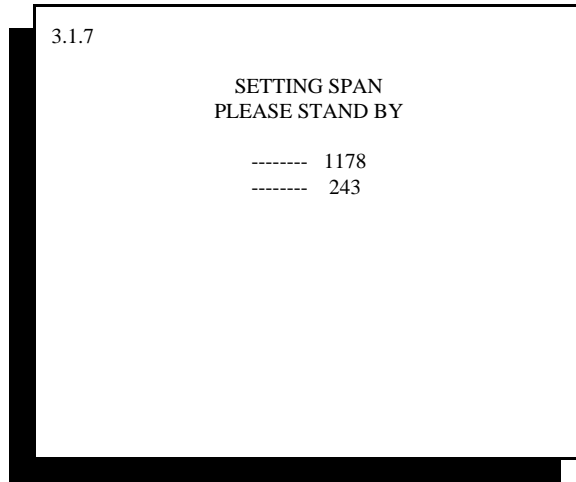

Calibration Span Screen

As with sub-menu 3.1.5, the values within this screen automatically adjust. There is no need for operator input at this time. Upon completion of these variable adjustments, the controller automatically advances to the next screen.

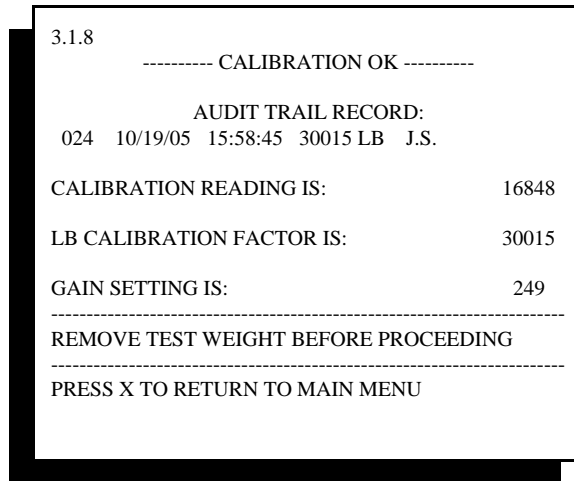

Calibration Completion Screen

This last display shows all data calculated during calibration. These constants are now stored in EEPROM (electrically erasable program read only memory), which does not require battery back up.

A portion of this data is also stored in a serial EEPROM that resides on the #474 Scale Digitizer, along with time and date, and audit trail name entry, and will be useful in future applications requiring audit trail information for scale certification. (Certification not available at this time)

Although this may first appear to be a rather complex operation, in truth it goes very quickly and with little chance for error.

3.4 Calibration Errors

There are several error screens that reside within the calibration routine. The data within these error screens should be recorded for reference when discussing calibration problems with a service technician. In most cases, the errors are caused by a problem with the scale, and relate to the controller's inability to properly span the scale due to load cell damage or weigh station mechanical restrictions.

The four error screens are:

"Cannot Zero Scale"

"No Test Weight On Scale"

"Span At Either Max Or Min"

"Cannot Write to Serial EEPROM"

"Cannot Zero Scale" is typically encountered when the load cell output is at either zero millivolts or below, or is greater than 30 millivolts. Check the load cell mount for mechanical restrictions such as improperly adjusted shipping bolts within the scale, or mechanical binds caused by interference of the weigh station conveyor with up or down stream conveyors.

"No Test Weight On Scale" is displayed if the millivolt output of the load cell when the test weight is applied is either no different than or only slightly different than the reading without the test weight applied. This usually indicates that either the test weight is too small, the load cell is damaged, or shipping links have not been removed from the scale.

"Span At Either Max Or Min" indicates that the digital potentiometer used to adjust Span is either adjusted to its minimum or maximum value, and that the Span of the load cell cannot be captured. This typically indicates one of two problems. The first is that the size of test weight used in proportion to the load cell full load capacity is not adequate to induce the minimum required offset between the zero established in the first part of calibration and the current load cell reading. The controller requires a minimum of 2.5 mV offset between the zero reading and the test weight applied reading. Use of a larger test weight typically remedies the problem. The second possibility is that either the #474 card or the load cell are damaged and should be tested and/or replaced.

“Cannot Write To Serial EEPROM” the calibration procedure requires writing and reading to the serial EEPROM that resides on the #474 Scale Digitizer card. If data cannot be written and stored, the calibration procedure cannot be completed. Although not typical, it is possible that some corrosion has occurred between the busboard’s card edge connector and that of the #474 scale card, and data is either not properly transmitted or not transmitted at all. Usually removing the #474 card and cleaning the edge connector will solve this problem. If it does not, it may be that components on either the #474 card or #470 card are inoperable, and either card may require replacement.

3.5 Displaying Audit Trail Information

Audit trail information plays an important role in your maintenance and quality assurance programs. The audit trail acts as an "electronic seal" of the existing calibration constants by requiring the operator to input information, storing it along with other vital information such as time, date, occurrence number, and calibration constants. This feature used in conjunction with the Password protection available within the system allows for a degree of protection against false or inaccurate calibration executed by unauthorized personnel.

By accessing sub-menu #2 within the Calibrate Scale main menu displays up to the last 100 calibrations executed on your equipment. This data resides within a serial EEPROM on the #474 Scale Digitizer card and should be printed or written down before replacing an existing #474 card. If so desired, the factory will extract this data and provide a printed copy in the event your #474 card fails and needs replacement.

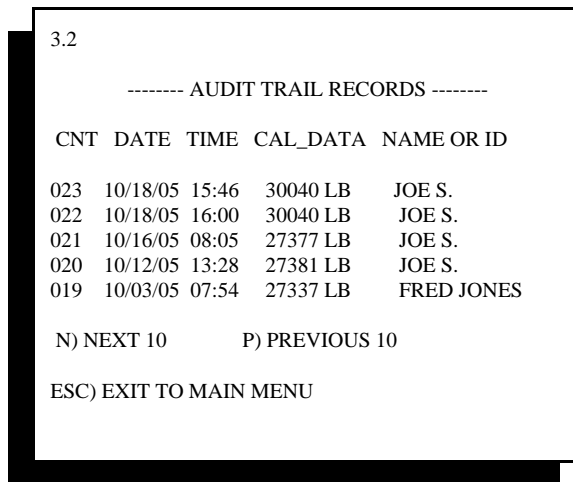

Audit Trail Data #3.2

The Audit Trail Records screen displays the last 10 calibrations in memory. To view the next 10 records, press "N" for next 10. The controller will display an end of file message when the last or first record is reached.

3.6 Print Audit Trail Records

The third sub-menu available at the beginning of calibration is to print the audit trail records stored in memory. To use this feature, you must have the STPR optional printer package (described in Chapter 8). Select item #3 from the sub-menu and the audit trail will automatically print.

Up to 99 audit trail records will be stored in memory. On the 100th calibration of the system, the records will "roll over" and write over the oldest record, which is record #1. Data in record #1 will be lost and replaced by record #100.

3.7 Calibration Theory

The Checkweigher system utilizes a weigh station conveyor for transporting product across the scale, and a load cell or flexure type scale base with load cell rated for a full load capacity that exceeds the dead load weight of the conveyor and at least twice the weight of your heaviest product.

Once the weigh station is assembled, the dead load weight of the conveyor is removed through a Zero function during calibration, leaving a full load operational range of approximately 30%-50% of the scale. The Checkweigher software derives an operational range for the scale based upon both the remainder of scale capacity left after applying deadload and the size of the test weight used to calibrate the scale. Typically the operational Checkweigher range is equal to slightly more than 50% of the test weight used.

The load cell residing below the conveyor is excited by a precision 10 VDC power supply generated by the #474 Scale digitizer card. This voltage is passed through the load cell's four resistive elements, commonly known as a 'Wheatstone Bridge'. Return voltage is received from the opposing poles of this bridge, filtered, amplified, and digitized by the #474 card's components. The resistive value of the load cell bridge assembly changes proportionally to applied load, thus weight can be detected through the change in this value.

Within the #474 Scale digitizer card resides an operational amplifier and Analog to Digital converter. These components and the controller's program generate an operational "window" in which weighments occur. That is to say, the controller does not utilize the full operational range of the scale base, but only a small portion of the remaining live load. (full load minus dead load) The span function of the calibration procedure finds the optimum ratio between the test weight value and the operational range of the scale. Therefore, the controller is capable of producing a resolution and accuracy based upon the remaining operational range of the scale.

Typically, scale systems offer a resolution between 5,000 and 30,000 divisions of the scale's full load capacity. Your Checkweigher system is configured for approximately 10,000 divisions. This again is based upon the true operational range of the scale, not on the full load capacity of the scale base load cell.

In the Setting Span procedure of calibration, the controller uses an internal successive approximation algorithm to obtain the correct ratio for operating the scale. By applying a known weight value to the weigh station conveyor and scale, the controller generates an internal multiplier to obtain a numeric value proportional to the applied load. This is why it is critically important to use a certified test weight when performing calibration. All other factors of weight are based upon the accuracy of the test weight.

Chapter 4

Controller Set Up

The Model 4693 Checkweigher controller is an embedded system design using a Z80 family microprocessor. All functions of the 4693 are processed by the #470 CPU card located far left in the card rack within the enclosure. All system inputs, outputs, and scale readings are queried and controlled by the CPU. The CPU also monitors the front panel membrane key board and drives the LCD display.

All adjustable operating parameters, including calibration, are accessed through the front panel key pad, with prompts for each of these parameters displayed on the LCD. The system Main Menu offers easy access to all system variables. Each of the Main Men choices are presented with logical, interrelated items, such as calibration, product set-up data, time, date settings, and statistical and diagnostics grouped individually

4.1 Setting Up the Controller

Once the 4693 controller has been installed and is ready for use, turn the Power ON/OFF switch located on the #472 Power Supply Card to the ON position. The controller will take a few moments to refresh the screen as it goes through its normal power up sequence. Upon power up, the controller defaults to the last screen displayed before being turned off. Press "X" to exit to the system **Main Menu**. This menu offers access to all system adjustments, settings, and calibration. Please note:

Every 4693 controller has its initial configuration values entered at the factory. This also includes a rough calibration on our system simulator. Your system must first be properly calibrated to your specific weigh station scale. **See Chapter 3 for Calibration Instructions.**

The Main Menu offers access to all adjustable settings within the controller. If you are not familiar with these menus, take a few moments to step through them. The Main Menu screen is shown below.

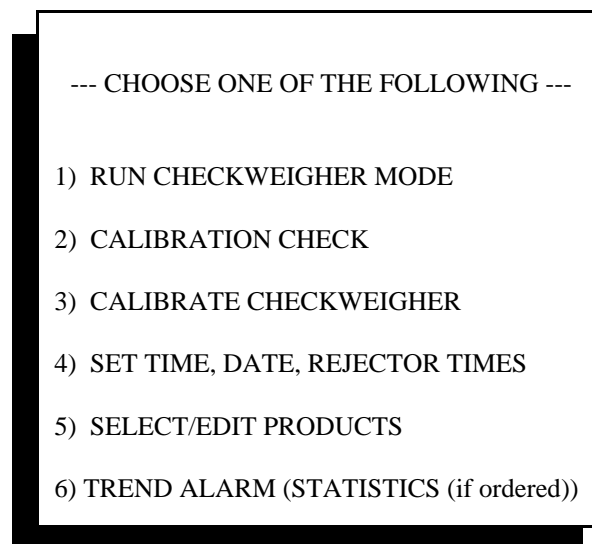

Main Menu

4.1.1 Main Menu Item #1: Run Checkweigher Mode

The Checkweigher mode is the "default" for this system. Once calibrated and products set up, the Checkweigher controller will normally be left in this setting. If power to the Checkweigher controller is interrupted or turned off, this display will automatically appear once power is re-established, and a valid calibration is found in memory.

50.00 LB				
NET		AZ		
LOW REJECT	LOW PASS	GOOD	HIGH PASS	HIGH REJECT
08	129	650	83	12
TOTAL UNITS		MEAN	TOTAL WEIGHT	
19037		50.04	952611.48	
RUNNING PRODUCT #01				
RED WIDGETS				
TARGET 50.00		TARE 0.33		
ESC) EXIT M) MEAN P) PRODUCT R) REPORT				

Checkweigher Run Screen

The Checkweigher Run mode display gives instant status on each package weight. Weight is displayed in large bold characters followed by the weight conversion symbol, i.e., kg., lb., oz., g. The weight display is updated each time a package crosses the Checkweigher weigh station, and the value remains displayed until the next package is weighed. Weight display also contains a Net or Gross indicator at the far left of the weight display. This is selectable depending upon the container weight value (TARE) entered for the particular product being run.

Directly below the weight display is a five (5) zone display. Zone displays are; Low Reject, Low Pass, Good, High Pass, & High Reject. Each zone tolerance is set through Menu selection #5, "Select/Edit Product". Zones are set with Low and High Reject as weight values as opposed to actual errors, that is, if the Target Weight is set at 50.00 lb, Low Reject may be set at 49.50 and High Reject at 50.50. These settings are for the lowest or highest acceptable package weight. Any package equal to or exceeding these values will be rejected. Low and High Pass zones are usually set at one-half the value of the corresponding reject value. Therefore, Low Pass would be set at 49.76 and High Pass at 50.26. All weight values falling between 49.76 and 50.26 would be classified as "Good". Corresponding zone outputs are generated by the #473 I/O card. Each zone output remains on until another package weight is generated.

As a package is weighed and classified, the correct zone output is actuated, and the correct zone box on the display will be turned to reverse video (black with white letters). This allows the operator to determine the package's zone classification from a distance as great as 40 feet.

Beneath each zone is a counter, which is incremented each time a package weight falls within that zone. Zone counters have a range from 0 to 99999. If the counters are not reset, they will automatically roll over to 0 once this limit is met.

Below the zone displays and counters, about mid-point on the screen, the current product number and product type is displayed. The 4693 is capable of retaining up to 75 individual product set up's, each with its own zone tolerances, target weights, and container weights. Provisions are made within these set up's for input of product type or lot number as well as other data. Each product set up is assigned a product number. The first product entered into memory will be product #1, next is product #2, and so on.

4.1.1.1 Menu Quick Keys

The bottom two lines on the LCD display contain "Quick Key" prompts that provide fast access to commonly used features. These include:

- X) Return to Main Menu
- P) Product Load
- M) Mean Unit Weight Adjustment
- R) Report Menu (Not shown if STPR package is not present)
- T) Down-Time Logging (Not shown if StatPak-PC is not present)
- C) Clear Zone Totals

Pressing the "X" key will exit from this display and will return you to the Main Menu. With the exception of Main Menu item 2 (calibration check), and 3 (calibrate Checkweigher), the Checkweigher continues to operate as a Checkweigher, weighing each package as it crosses the weigh station. Zone outputs, counters and rejects will still operate while changing or selecting product types, setting time or date, or working within the statistical data sub-menus.

Pressing the "P" key will display a secondary screen allowing the operator to load a new product type to run. That is to say, if multiple product set-up's exist in the controller's memory, and the operator is currently running one product type, pressing the "P) Product Load" key will allow quick and easy access to loading any of the other existing product types.

Pressing the "M" (Alternate "A") key will present a display for adjusting or clearing the Mean Unit Weight value displayed on screen. Mean unit weight is essentially the average of between 2 and 100 unit weights. The operator can select the value desired, between these two limits. This value is updated every time the entered value is reached. Other choices are presented as well, as shown below:

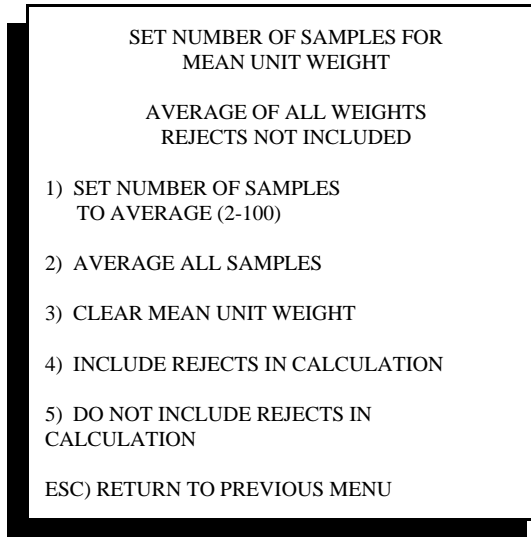

Average or Mean Setting

If item #2 “Average All Samples” is selected, the checkweigher will display the tag “AVG” in the center box on the Run screen, just below the zone boxes. The average will be a simple math calculation of the average of all the past weight values, either from the time a new recipe was loaded or the average was cleared.

If item #5 “Do Not Include Rejects In Calculation” is selected, the Mean or the Average will be modified and based only upon weight values that fall within acceptable weight parameters for the current recipe.

Pressing the “R” key will present a display containing selections for turning on and off unit weight listings, calling interim or final summary reports, or clearing statistical data from memory. These selections are only present when the optional STPR reporting package has been purchased and installed.

Pressing the “T” key will present the user with a list of information on current production performance; total elapsed time for the production run, total up time (actual running time), total units weighed, total units per hour average, and total percent of down-time in percentage, based upon total elapsed time divided by total up time. This key selection is only present when the optional StatPak-PC data logging & reporting software has been purchased, along with the #477 serial communications card that installs into the checkweigher’s card rack. If this option has not been purchased and installed, this prompt will not appear on the screen.

Pressing the “C” key will clear all zone totals currently displayed beneath each zone. If your Checkweigher includes the STPR printer package, clearing the zone totals will Not affect data collected for reports.

4.2 Setting Time, Date, and Rejector Settings

Select item #4 "Set Time, Date, Rejector Time" from the Main Menu. A series of screens will follow prompting the operator through setting each of these variables. Each of these screens are shown below for reference.

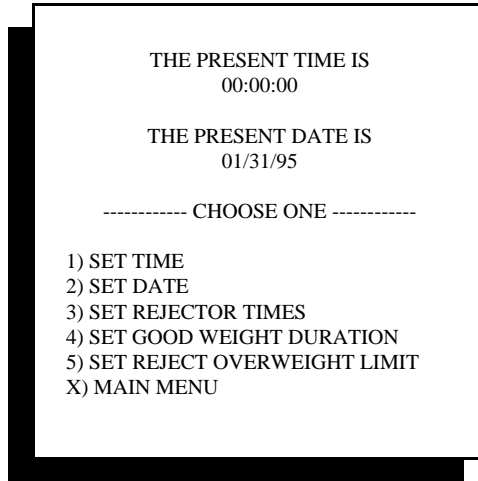

Main Menu #4

4.2.1 Setting Current Time

To set the time, select submenu item number 1. The following screen will appear:

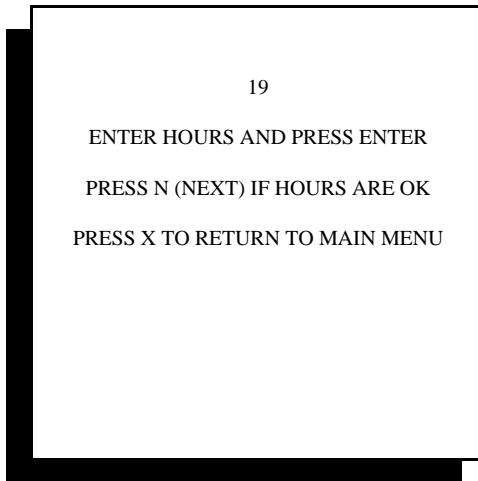

Setting Hours

Hours are entered in the 24 hour format. For example, 8 O'clock in the morning would be input as 08 hours. 8 O'clock in the evening would be input as 20 hours. Simply add 12 to the time from 1 p.m. until midnight.

The next menu screen is for input of minutes. This screen is exactly the same in appearance as the Hour input screen shown above. Simply input the number of minutes, with minutes 0 through 9 entered as 00, 01, 02, etc. After the entry of minutes, another screen will appear for the input of seconds. This is typically not a critical setting, and the default (00) can be selected by choosing "Return to Main Menu".

Upon returning to the Time/Date/Reject menu, you have the opportunity to set the current date. It is important to enter both time and date for use in the calibration audit trail. Calibration cannot be completed until a current time and date have been entered into the controller.

4.2.2 Setting Current Date

Date is entered essentially the same way as the time. The first submenu offers the input of the current Month followed by Day, and Year. Please keep in mind that this version software allows for the input of American Standard Date Format, which is MM/DD/YY (month, day, & year).

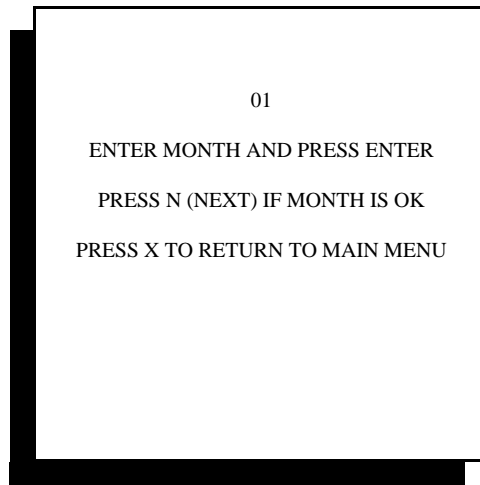

Date Menu

As with setting time, you can advance from Month to Day to Year by pressing N for next menu after entering the current information.

4.2.3 Setting Rejector Times

The Checkweigher controller default reject output configuration generates a single timed reject output for low-reject weight, high-reject weight, and metal contaminated product. An input is provided for an up-stream metal detector's reject output connection.

The Checkweigher controller can also be configured to operate these outputs separately and in conjunction with a metal detector. Settings for the default single low/high reject output are described in this portion of the manual. For description on setting other reject output configurations and their operation, refer to Chapter 5 "Controller Configuration".

The single low/high reject output is controlled by two internal timers:

Delay Time is the time that elapses between the actual moment the package is weighed and the time it takes to reach proper positioning at the reject device.

Duration Time is the time the reject output signal is held actuated.

A weighment occurs as a package enters the weigh station conveyor and travels across the conveyor. The weight of the package is detected by the Checkweigher controller, and as the load increases, the controller generates an internal "ramp" of weight samples. Once the package is completely on the weigh station, this "ramp" flattens out since the weight is no longer increasing. As the head of the package touches the down stream conveyor, the weight of that package begins to decrease. This "down ramp" of weight samples is detected by the Checkweigher controller, and the weighment cycle is terminated.

Upon termination, the controller makes several calculations and generates a final weight value for that package. Termination occurs when the leading edge of the package exits the weigh station onto the down stream conveyor OR when the Early Weight Terminate photo-eye located at the exit end of the weigh station is blocked by the package's leading edge. This is the moment when the Delay Time timer begins to count down.

When connecting directly to a reject solenoid or device that has complete control of the reject device solenoid, it is good general practice to set Duration Time to 0.0, and run a package across the Checkweigher. Using a stop watch, note the amount of time required for the package to reach the reject device once the weight value of that package is first displayed on the Checkweigher controller.

Once this time is approximated, input a Duration Time of 0.1 second so that the reject solenoid can be actuated without actual discharge of the package. This allows for adjustment of the Delay Time without the possibility of destroying a package in the process.

In many cases, the Checkweigher's reject output is tied to the system **PLC (programmable logic controller)** used to operate other portions of the packaging line. In turn, timing for operation of the reject device is handled from the PLC. In these cases it is usually recommended that our Delay Time be set to 0.0 and Duration Time set to 0.2 second to generate a "pulse" input to the PLC. Please check with your system integrator or packaging line equipment manufacturer for details on this interface.

Below is a sample screen for the Rejector Time submenu. As with all menus, simply follow the directions on the screen to complete the input of data.

1) LOW, HIGH, & METAL REJECTOR DELAY	0.5 SEC
2) LOW, HIGH, & METAL REJECTOR DURATION	1.3 SEC
5) METAL DETECTOR DELAY	0.9 SEC
X) RETURN TO MAIN MENU	

Reject Output Timer Menu

Refer to the troubleshooting guide in Chapter 6 for information on diagnosing problems with rejector output signals.

4.2.4 Good Weight Duration Time

The Checkweigher controller can be outfitted with an optional second I/O card to provide an output to acknowledge a "good" weight. (A weight that falls between Low Pass and High Pass) This output time is set by selecting item number 4, "Set Good Weight Duration" from the Time/Date Reject Time menu, as shown below.

---CHOOSE ONE ---
PRESENT GOOD WEIGHT DURATION TIME
1.0 SEC
---ENTER NEW DURATION TIME ---
0.0
--- MAX 5.0 SEC ---
ESC) RETURN TO PREVIOUS MENU

Good Weight Time

4.2.5 Set Reject Overweight Limit

The reject overweight limit is for applications where material weighed on the Checkweigher and rejected is returned either to the mixer, batch system or for re-work. This setting accumulates the maximum amount of weight that can be rejected and re-worked. When that amount is reached or exceeded, Output #7 on the I/O card will be actuated as an alarm.

When the alarm occurs, it will remain on until acknowledged at the Checkweigher controller front panel.

Following are screens for setting the reject overweight limit and the alarm screen:

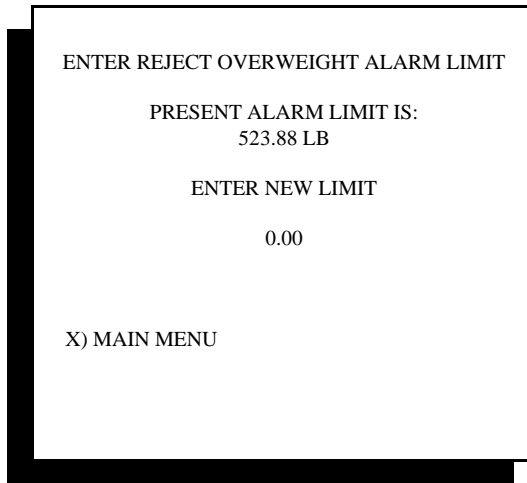

Reject Overweight Limit Screen

Enter the amount of acceptable re-worked product, up to 99999.99

When this value is exceeded during production checkweighing, output #7 on the 473 I/O card will be turned on. This output will remain on and an error screen will be shown on the Checkweigher controller. The Checkweigher will continue to weigh other product crossing the scale during this alarm condition.

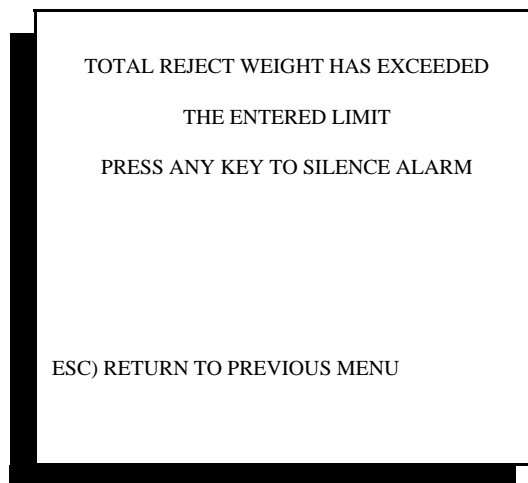

Reject Overweight Error Screen

4.3 Product Recipe Entry & Edit

The Checkweigher controller is capable of storing 75 unique product recipes in memory. Each of these recipes include important data such as: Target Weight, Reject Limits, Container (TARE) Weight, and Product I.D. information.

The Main Menu provides access to entry of new product recipes and editing of existing recipes through Menu item #5 "Select/Edit Products". Once a product recipe has been entered and saved, it can be edited at a later time or called from the Run Checkweigher screen (Main Menu Item #1).

In the "Run Checkweigher" screen, a quick key prompt at the bottom of the display labeled "**P) PRODUCT LOAD**" allows quick access to selection of any existing product recipe. This prompt allows the operator to select another product to run without exiting from the main Checkweigher display. If product #1, Big Red Widgets are currently being run, and production requires a change to product #27, Big Blue Widgets, the operator presses "P" and a secondary screen appears asking for the new product number. #27 is entered, and the controller automatically loads product 27 as the new current product. Systems with the optional STPR production reporting package or StatPak-PC software automatically generate production summary reports or close the data file for later reporting. See Chapter 8 for details on STPR and StatPak-PC options.

To enter a product recipe or edit an existing recipe, select item #5 "Select/Edit Products" from the Main Menu. A sample of this screen is shown below:

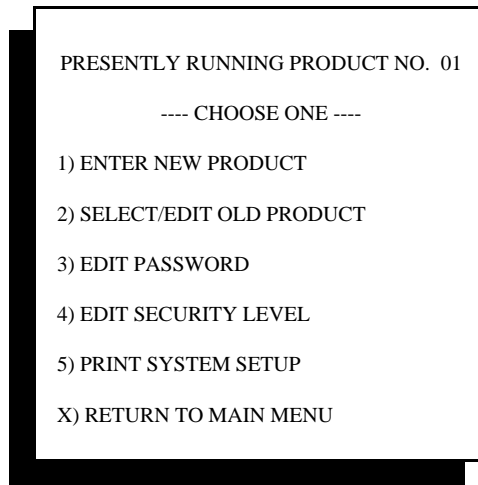

Main menu #5

Each of the 5 menu items are described below in detail.

4.3.1 Entering a New Product

The Checkweigher controller must compare the actual weights crossing the scale to a reference, which is called the Target weight. This Target weight value is then compared to other values, such as minimum and maximum weight error (low and high reject limits). A TARE value or Container Weight can also be used to display the calculated Net weight of the package

New products or product types should be entered as a unique product recipe in the controller. Selecting #1 from the Select/Edit Product Main Menu allows for the input of new product recipes.

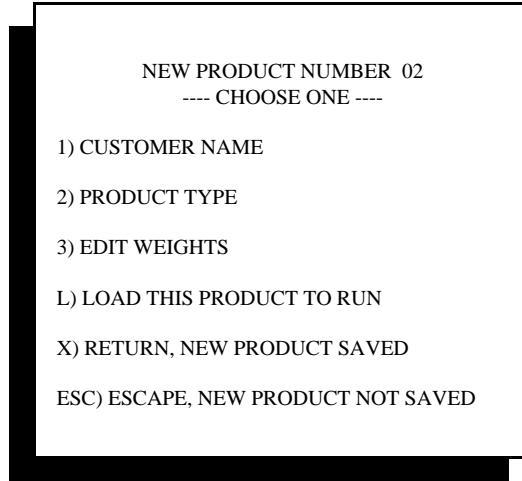

New Product Menu

Data fields are provided for entry of “Customer Name” and “Product Type”. These fields are associated only with this product recipe and are displayed in the “Run Checkweigher” screen, below the zone boxes. Any type of data, up to 28 characters, can be entered into these two fields.

Selecting submenu item #3 "Edit Weights" will step you into another submenu requesting the input of the current password. A password is provided at this point to protect changes to weight values and parameters by unauthorized personnel. See **Password Entry** in section 4.3.3 below for more information on this feature.

Once the password has been entered, the next screen will appear as shown below. Data is entered into this menu by selecting the proper parameter to adjust and entering numerical data only. Decimal points are fixed and cannot be adjusted in these menus.

---- CHOOSE ONE ----		
1) HIGH REJECT		50.50 LB
2) HIGH PASS		50.25 LB
3) TARGET WEIGHT		50.00 LB
4) LOW PASS		49.75 LB
5) LOW REJECT		49.50 LB
6) CONTAINER WEIGHT		0.60 LB
	L) LB	K) KG
X) RETURN	O) OZ	G) GRAMS

Weight Parameter Menu

Target weight is typically input as a NET weight value. That is to say it does not include the weight of the package your product is in. If you choose to set the Container Weight (TARE) to zero, then Target weight is considered a Gross weight value.

High and Low reject limits are input as the actual reject weights for this product. A package entered with a 50.00 lbs. Target Weight and reject limits at 49.50 and 50.50 respectively would allow a package weighing 49.52 or 50.48 to pass through the system, but would reject a package weight of 49.50 or 50.50 Lbs.

High and Low pass values are typically input at one-half of the reject limit and are useful for the operator viewing the main checkweigh display. Product weights that begin to drift slightly from the Target or "Good" zone would alert the operator by showing more and more weights falling within the High or Low Pass zones. These zone settings are also useful when operating a remote zone light display.

This screen also shows a selection of weight conversions; lbs, kg, oz, and g. If the system has been calibrated in either lbs. or kg, then weight values in this menu can be entered as either lbs. or kg. However, if the Checkweigher has been calibrated in oz., then only ounces can be entered in this menu. If the system has been calibrated in g., then only grams can be entered into this menu. Attempting to select a non-compatible weight conversion to that used in calibration will result in an error.

Once all data has been input, **press "X"** to return to the "Enter New Product" menu. This menu (#4.3.1 shown above) allows two options for exiting back to the Main Menu. The first choice is to **select "L" to load the new product to run**. This saves all data entered, and loads it as the current product to be run by the Checkweigher.

In cases where a current product is being run across the Checkweigher and new product recipes are being entered within these menus, **select "X" to return to the main menu and save the data without loading it to run as the current product**.

A third choice allows for **exit to the main menu without saving any of the data just entered**. This is done by pressing the Esc button.

4.3.2 Editing an Old Product

Once products have been entered into the controller, you may wish to change a setting, weight limit or product I.D. value. To do this, select item #2 from the “Select/Edit Product” menu.

Entering this menu selection will present a prompt on the screen asking for the number of the recipe to be edited. Once entered, the Customer Name, Product Type, along with several other menu choices, will be displayed. If this is the correct recipe to edit, select the fields to be changed or enter into the “Edit Weights” menu to adjust Target or reject limits. The display also contains two prompts labeled “N” for Next Product, and “P” for Previous Product. By entering either of these two letters, you can scroll through all products in memory.

As with the Enter New Product Menu, you must enter a password, if enabled, to edit the weight values. You must also select "L" to load the new product values to run as the current product, or select "X" to simply save the changes and exit from this submenu.

4.3.3 Edit Password

The Checkweigher controller contains password protection for the entry of product weights such as Target Weight, and High/Low Reject Limits. This password also protects execution of calibration.

Each system is shipped from the factory with a null string (space) entered as the password. This allows total access to every feature of the system without the need to enter passwords. To enter a password, select item #3 from the “Select/Edit Products” menu. The following display will appear and allow the entry of up to 10 characters for the password. The password can be constructed of any alpha-numeric characters with exception of special characters such as ., -, *, or /. Each character will be displayed as an asterisk (*) when entered, and will also display when actually entering a password during normal operating conditions.

In cases where the password is forgotten or incorrectly entered, you may select Item #3 from the “Select/Edit Products” menu, and at the "Enter Password" prompt, type the following string.

SCALE



Password Entry

4.3.4 Edit Security Level

The Checkweigher includes a single level of password security for calibration and product recipe, as described above. In addition, an optional key switch can be added to the controller cabinet to provide a physical means of locking out unauthorized personnel from calibration, recipe editing or both. In addition, a global lock-out keeps the operator in the “RUN” screen only.

A set of digital inputs (logic level) are provided on the #476 card, located inside the controller door, just below the LCD display. See the controller layout drawing and interconnection diagram in Appendix D for specifics on wiring to these inputs.

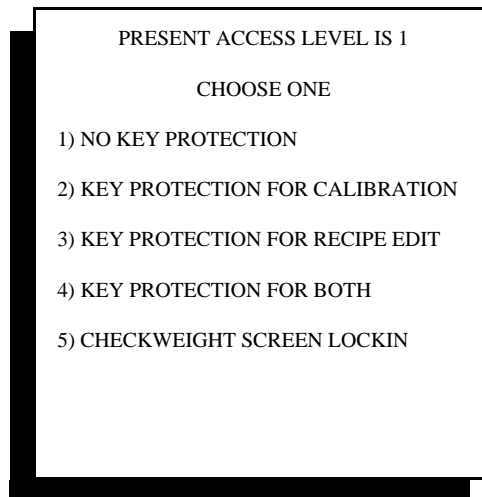

Security Keylock

4.3.4.1 No Key Protection

This is the default state. A key is not required, and password can be either enabled or disabled to protect both calibration and product recipe entry or edit.

4.3.4.2 Key Protection for Calibration

This requires proper input of the keyswitch to allow access into the calibration routine. Password is disabled for this setting.

4.3.4.3 Key Protection for Recipe Edit

This requires proper input of the keyswitch to allow access into the product recipe edit screen. Target weights and/or reject limits cannot be adjusted without the use of the keyswitch.

4.3.4.4 Key Protection for Both

Use of this configuration overrides the password, requiring the keyswitch to access either calibration or product recipe edit.

4.3.4.5 Checkweight Screen Lockin

When this item is selected, and the keyswitch is turned to the key removal position, the checkweigher controller will remain in the "Run Checkweigher" screen. The operator will have access to all current information shown in this screen, and will have the ability to load a product to run, and can operate all functions of the optional StatPak-PC data logging or STPR reporting package.

4.3.5 Print System Setup

Checkweigher systems that have the optional STPR statistical analysis package installed (see Chapter 8) will display menu item #4 in the Enter/Edit Product Main Menu. This feature will automatically down load all product data to your printer package providing you with a hard copy of product types entered into the controller. This printout is also helpful in providing a "work sheet" of sorts for working out the details of each product type before actually entering the data.

PROD. NO.	CUST	I.D.	TARGET	CNT. WT.	LO REJ.	LO PASS	HI REJ	HI PASS
01	YOUR NAME	LOT 12	50.00 LB	0.60	49.50	49.75	50.50	50.25
02	THEIR NAME	BATCH 3	25.00 KG	0.30	24.78	24.88	25.36	25.16
03	-----	-----	-----	-----	-----	-----	-----	-----

Product Listing Report

Reports will print only the number of products you have entered into the system. If there are no products entered, only the headings will print. This report can be called at any time during production or when the controller is not in use.

As with all menus in this controller, hitting the "X" key will step you back to the previous menu.

4.2 Minimum System Set Up

The Model 4693 Checkweigher Controller requires a minimal system set up to begin using the Checkweigher system. These minimum requirements are:

1. System Calibration
2. At Least One Product Set Up
3. Reject Delay and Duration (if reject device is used)

System Calibration is covered in detail in Chapter 3, and should be executed before attempting to use your Checkweigher system.

Calibration is required to provide an accurate and reliable weights. Product recipes provide the operating parameters for the controller to determine the correct target weight and reject limits for packages currently running across the Checkweigher weigh station.

Chapter 5

Controller Configuration

The Checkweigher controller contains an extremely versatile program with many options and settings that can accommodate many different applications and accessories. It also offers a wide variety of settings used to tailor the controller to meet your specific needs. The factory sets default settings, according to the type of accessories and options purchased with the original equipment. Resellers or system integrators may further modify these settings to meet the application's specific needs.

The last page of this chapter contains a list of system configuration defaults for your specific type of Checkweigher. These can be used to restore your controller to its original configuration or to configure a new CPU card that may be installed into the controller.



CAUTION: CHANGING THE DEFAULT VALUES OF THE VARIABLES NOTED BELOW MAY ADVERSELY AFFECT THE PERFORMANCE OF THE CHECKWEIGHER

Instructions within this manual and attached drawings are to be strictly followed to insure both personnel safety and proper operation of the equipment. Please read carefully before attempting to install or operate this equipment.

To access the configuration menu, you must first exit or Escape back to the Main Menu.

Hold down the Shift key, and type **EXIT**. Upon striking the "T" in EXIT, the screen will change to the configuration menu.

You may exit this menu at any time by hitting **Esc** until you return to the standard Main Menu.

5.1 Configuration Menu

1) SET A-D SAMPLE RATE	24
2) SET FILTER FREQUENCY	05
3) SET NUMBER OF FILTER SAMPLES	8
4) SET MAX PRODUCT NUMBER	02
5) SET #1 A-D GAIN NUMBER	204
6) SET DECIMAL POINT	02
7) DISPLAY SLOPES	
8) GET NEXT MENU	
Esc) RETURN TO MAIN MENU	

Configuration Menu #1

5.1.1 Setting Sample Rate

Internally, the Checkweigher controller makes over 500 analog to digital conversions per second. This is a read of the load cell output and conversion to a digital value by the 474 card's circuitry, which is then transferred to the 470 CPU. Sample rate setting selects the number of samples used in weight averaging routines and in the base Checkweigher program.

Sample rate has an adjustable range up to 200 samples per second, but it is recommended that this value be kept between 24 and 160. The higher values are typically used by Thompson Scale's line of small package Checkweighers, and serve no practical use for the heavy-duty equipment.

5.1.2 Setting Filter Frequency

The Checkweigher controller contains a 5-pole low pass filter that offers an adjustable frequency from 1 to 25 Hz. The factory default setting is 5. In mechanically "noisy" environments it may be necessary to adjust this value lower to filter out vibration induced into the scale mechanism. Decreasing this value will slow the system's responsiveness as a result of heavier filtering, and attention should be paid to final weights to confirm that accuracy remains intact.

5.1.3 Setting Number of Filter Samples

The filter samples setting refers to the number of samples averaged to obtain weight. This filter is a sliding-average filter, where a set group of either of 8, 16, or 32 samples, receive data from the load cell and are updated based upon the Sample Rate set in 5.1.1 above. As a new weight sample is received, the oldest is removed from the set. A new average is calculated from the updated sample set, and its value is then placed in memory and compared to previous samples.

The default setting is 8. Increasing this value to 16 or 32 will require a longer period of time to average since more samples are required. Increasing the Sample Rate at the same time will diminish the time required to acquire the number of samples, in turn reducing the time required to calculate the new average. If the filter sample value is increased to 16 or 32, and the Sample rate is left at the factory default of 24, the Checkweigher may no longer be capable of detecting and properly weighing product.

5.1.4 Setting Max Production Number

The Checkweigher controller is capable of retaining 75 unique product recipes in non-volatile memory. If for some reason it is determined that invalid data is stored in these memory locations, or if you decide to "wipe the slate clean", you can change the value displayed in "Setting Max Product Number" to a value of 02. This will give you one initial recipe to start with. This is typically done at the factory and never requires modification. As new recipes are added, the number in this variable will automatically increase to show the number of recipes held in memory, plus one.

This value is always one greater than the number of product recipes in memory. **DO NOT SET THIS VALUE BELOW 02!**

5.1.5 Set A/D Gain Number

The A/D setting is a value set internally by the Checkweigher controller. It is not an adjustable value, and is only shown for reference. The nominal factory set value is 200. This value should remain between 170 and 250, and does not require any adjustment.

5.1.6 Set Decimal Point

The default setting is 02 for the decimal point. This value can be changed from 0 to 3, depending upon the full load capacity of the load cell and the package being weighed. Package weights from 10 to 110 lb., and using a 500 lb. load cell, require a setting of 02 decimal places. This will provide a weight resolution of 10,000 divisions.

A resolution of 10,000 divisions should not be exceeded. Contact the factory to discuss your accuracy needs and scale capacities.

5.1.7 Display Slopes

The Checkweigher program relies completely on load cell output to determine the presence of, and termination of weight of a package crossing the scale. Slope settings are used to set criteria for recognizing the entrance of a new package and termination of the package weight sample cycle. These values are critical to proper operation, and are set internally. Values are based upon a percentage of test weight used during calibration of the Checkweigher. These values are not adjustable, but are displayed as a source of information when troubleshooting the controller. If weight repeatability or accuracy problems arise with your Checkweigher, Thompson Scale's service technicians may ask for this data.

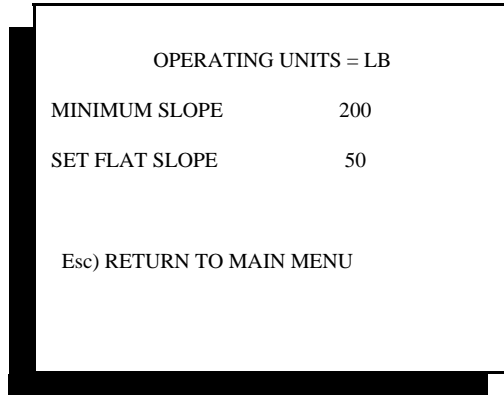

Slope Settings

5.1.8 Get The Next Menu

There are more configurations available than can be displayed properly on a single screen. Selecting #8 from the menu will display a secondary configuration screen containing additional variables, as shown below:

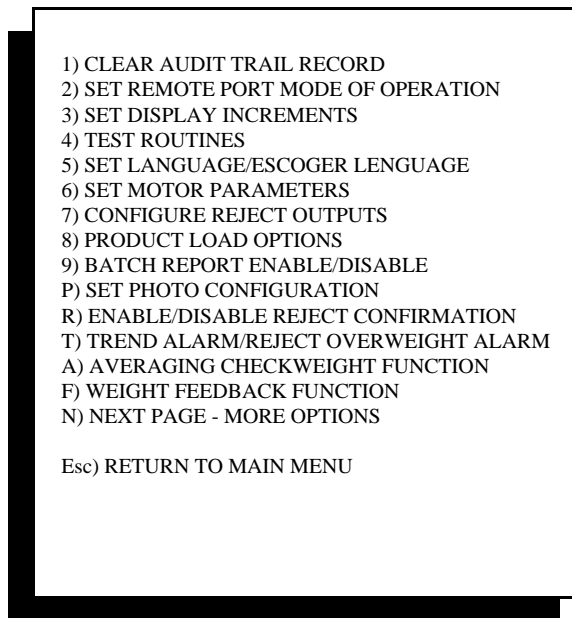

Configuration Menu #2

5.2 Secondary Configuration Screen

Each of the settings shown in the above screen example are described below:

5.2.1 Clear Audit Trail Record

Each time the Checkweigher is calibrated, important data is stored in the system's EEPROM (electrically erasable programmable read-only memory) This data cannot be changed or destroyed by loss of power or battery back-up, but only by purposefully erasing the data through this setting. Each audit trail record contains; calibration time and date, name or initials of person executing calibration, and a calibration factor. Up to 100 audit records are stored in memory, and can be viewed or printed from the calibration menu. Clearing this location in memory will destroy ALL calibration audit records that currently exist.

5.2.2 Set Remote Port Mode of Operation

The Checkweigher controller contains a "REMOTES" serial port, located on the face of the #470 CPU card. Information on use of this port can be found in Chapter 8, Section 8.1.4.

The serial port is a 20mA current loop port that can be wired either Active or Passive. This is NOT an analog output, and transmits out discreet ASCII data with a fixed protocol of 1200 Baud, 1 Start Bit, 8 Data Bits, 1 Stop Bit and No Parity. See Appendix A for more information.

This port transmits production data in either a continuous stream of data, or as discrete packages, one for each weighment that occurs. A configuration screen is presented upon entering this menu item, as shown below:

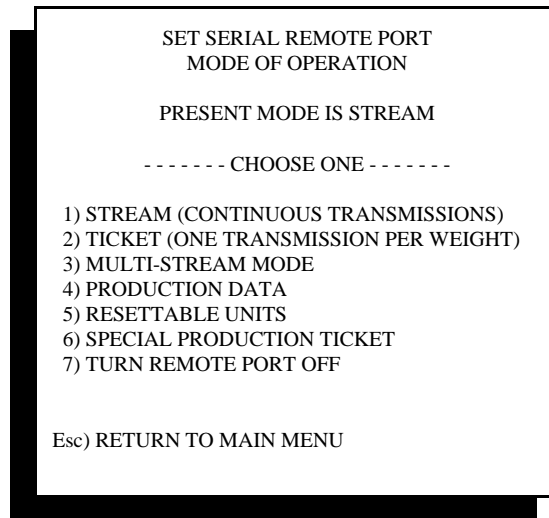

Remote Port Settings

As mentioned above, the remote port can be configured to transmit each unit weight in either a "stream" or continuous mode, which is often used with remote digital displays, or in a "ticket" mode, which is typically tied to a line printer or computer port for collection of weight data. A third mode, called "Multi-Stream Mode" allows for the transmission of several other types of production data that may be useful. This data only transmits in the "Stream" mode.

This port can also be configured to transmit any combination of the following strings of data:

Last Unit Weight	(Preceded by "A")	Total Weight	(Preceded by "B")
Total Units	(Preceded by "C")	Mean Unit Weight	(Preceded by "D")

In this mode, each set of production data is preceded by an alphabetic character to differentiate it from the other strings. As shown directly above, Last unit weight is preceded by the character "A", Total weight by "B", etc.

To select the item or items to be transmitted, select "Multi-Stream Mode" from the Remote Port Configuration screen. The following screen will be displayed:

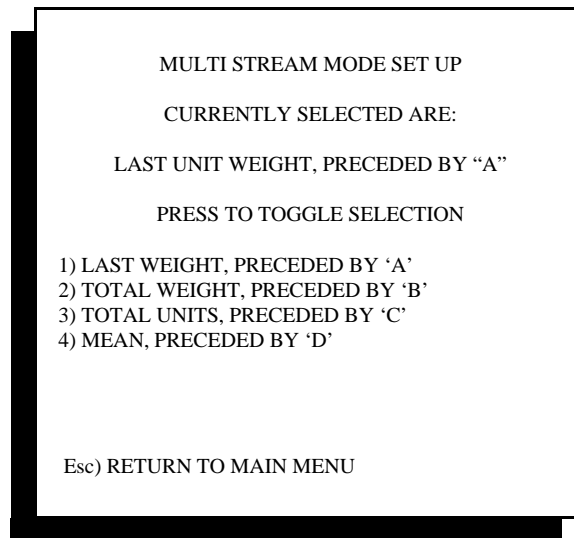

Setting Multi-Stream Mode

This screen will display the currently selected items to transmit, and allows for the inclusion or removal of any of the data strings by selecting the appropriate item from the list. That is to say, if the port is currently transmitting items #1 and #2, and you wish to remove item #2, select it to toggle the setting and remove it from the list of transmitted data.

Last Unit Weight transmits the last Gross or Net weight value weighed on the Checkweigher. This data is updated every time a unit crosses the scale.

Total Weight displays the current total weight, in either pounds, kilograms, ounces, or grams, whichever is the currently running conversion for the Checkweigher. PLEASE NOTE that this display can only display six (6) characters, which is the typical number of digits found in remote displays. If your Checkweigher is weighing pounds, with a displayed resolution of 0.00, then Total Weight will be displayed in total pounds only. The decimal portion of the weight will be truncated. If the weight value exceeds 999999 lb., the display will transmit the least significant six digits. For example, if you have weighed 1,893,754.23 lbs., this value will be displayed properly on the Checkweigher’s controller display, however the transmitted value will only be 893754.

Total Units will display the total units as displayed on the Checkweigher’s controller display. As with total weight, total units is only capable of transmitted the least significant 6 digits, so caution should be exercised if production runs equal or exceed 6 digits worth of data.

Mean value is the average of the last “x” number of units, as selected on the Checkweigher controller. This value is set from the “Run Checkweigher” screen (display showing last weight and production data), and can be found at the bottom of the screen. A prompt labeled “M) Mean” provides adjustment of the average of the last 2 to 100 unit weights, and can be cleared from this screen as well.

Item #4, “Production Data” is described in detail in Chapter 8 “Checkweigher Features”, Section 8.3.2 and 8.3.3. This mode makes available real-time production statistics on the Checkweigher’s display. Supervisory or quality assurance personnel can easily and quickly monitor production line summary data, including total productivity time for the run.

Item #5, “Resettable Units” performs a special and specific function, and is intended for use with Thompson Scale’s remote digital displays. This mode presents the operator with a unit count of production and the ability to reset the count to zero without disturbing accumulated count or other production statistical data at the checkweigher. For example, an operator running a form-fill-seal machine may need to run a lot of 200 units to complete an order. The operator presses the reset button provided with the remote display, setting the display to zero. As packages cross the checkweigher, the counter is incremented. When the count reaches 200, the operator knows to stop the FFS machinery. See interconnection diagram at the back of this manual for details on wiring the remote display and this optional input.

Item #6, “Special Production Ticket” transmits a lengthy string of data with commas used to delimit or separate the pieces of data. Data includes:

Field	Format	
Date	mm/dd/yy	
Time	hh:mm:ss	Military time (24 hour clock)
Weight	xxx.xx	Total of 7 characters, leading zeros and + sign suppressed. Will transmit negative sign if package weight is under weight reject
Product Type	xxxxx	Maximum of 6 characters, must be alpha-numeric
Package Type	xx	Maximum of 2 characters, must be alpha-numeric
Sequence #	xx	From 0 to 9,999,999 Automatically resets when product recipe is changes or reloaded

The complete string, including control and delimiting characters is:

<STX>mm/dd/yy<,>hh:mm:ss<,>weight<,>product type<,>package type<,>sequence number<,><CR><LF><ETX>

STX = start of string character

CR = carriage return

LF = line feed

ETX = end of string character

5.2.3 Set Display Increments

This menu item contains two interrelated settings. The first selects the increments displayed for the final weight and in the Calibration Check screen. The default setting for the Checkweigher is 2 increments. With a default decimal point setting of 2, the displayed resolution of the Checkweigher is in increments of 0.02 lb. If, for example, the display increment was changed to 1, the resolution would become 0.01 lb.

The second setting is for configuration of the auto zero routine used by the Checkweigher. This menu item is described below, after configuration of display increments.

The menu for these settings appears as shown below:

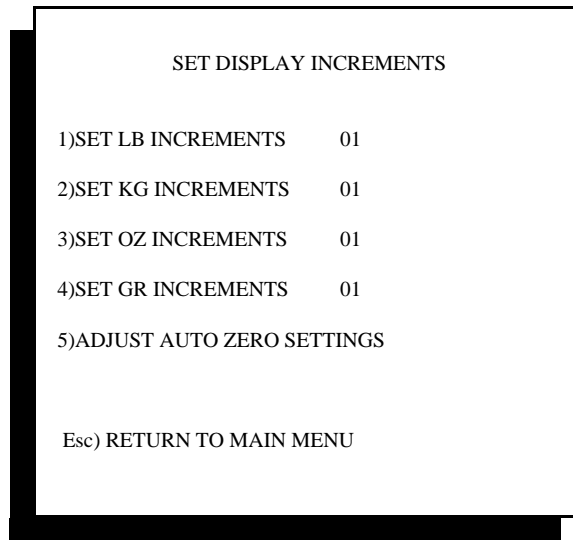

Setting Displayed Increments

5.2.3.1 Setting Display Increments

Separate variables are made available for LB (pound) KG (kilogram) OZ (ounce) and G (gram), as shown above. Ounces and grams are typically not available for use with the heavy-duty Checkweigher.

Upon entering into one of the display increment settings, a new screen will be displayed allowing you to select from three increments, which are 1, 2, & 5. No other increments of resolution are available:

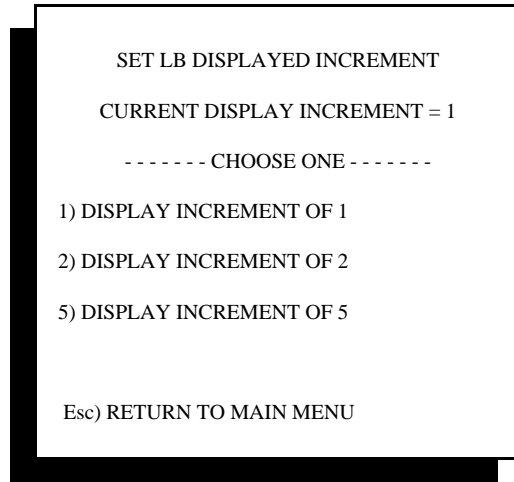

Setting LB Displayed Increment

5.2.3.2 Setting Auto Zero

The auto zero setting is a routine central to maintaining the accuracy and long-term performance of the Checkweigher. Product spillage and temperature variation will affect the scale if the controller does not perform regular maintenance of the system's operating zero.

The auto zero routine used in the Checkweigher controller can automatically zero any deviation from the current operating zero, up to 2% of the test weight.

Each time the auto zero updates, an indicator is shown in the Run Checkweigher screen. This indicator is in the upper third of the screen, in-line with unit weight and weight conversion (lbs., kg., etc.) and is located at the far right on the screen. When the zero is successfully updated the indicator "AZ" will appear on the screen.

A system zero is established during calibration, and is the reference for all future auto zeroing of the scale. Programming within the controller constantly monitors the output of the scale's load cell, and compares these readings to see if a package is entering, on, or leaving the scale. These readings are also compared to the system zero. If the readings are unchanging, within a narrow range, AND remain within this range for a set period of time, a new operating zero can be taken.

If the new zero is outside of the 2% range, described above, the Checkweigher's program will zero 50% of the difference and then search for a new zero using the same range and time constants to compare for a steady scale reading. This process will continue until the difference between the current and new zero are within the 2% range.

It is also possible to override this by going into Main Menu #2, Calibration Check, and manually zeroing the scale. See Chapter 3 for information on Calibration Check features.

The following menu provides access to both the range of acceptable change and the time constant to measure the change:

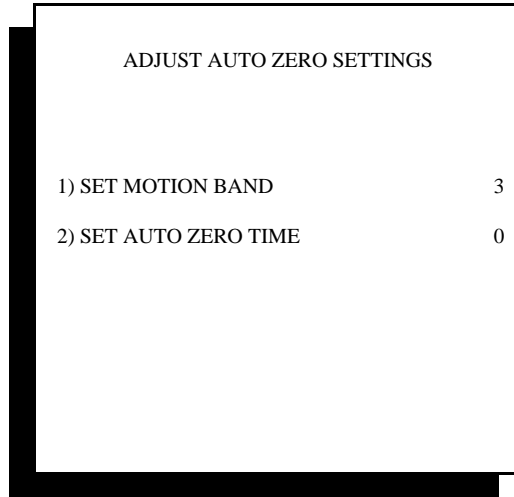

Auto Zero Settings

5.2.3.2.1 Setting Motion Band

The motion band sets the amount of variance that can be seen in consecutive scale readings and still be considered to be within an acceptable range for auto zeroing. Some applications may be subject to more vibration than others, and may not be capable of capturing the necessary consecutive samples required to perform a zero if this setting is too narrow.

The default setting for the Checkweigher is 3 display digits.

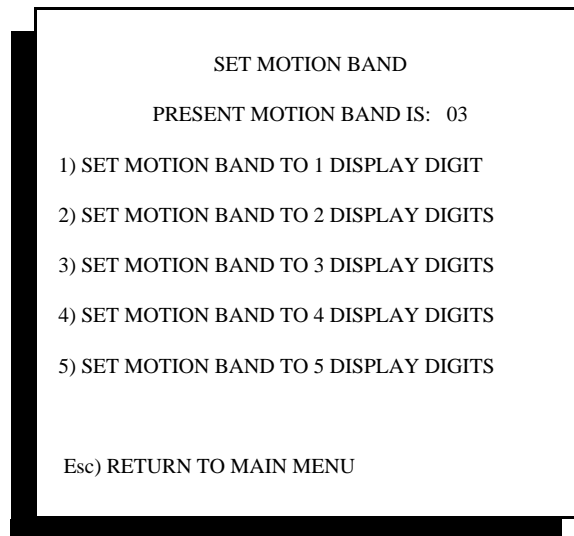

Setting Motion Band

5.2.3.2.2 Setting Auto Zero Time

The auto zero time setting allows the user to adjust the amount of time required to monitor the scale's motion band. A setting of 0 seconds will cause a new zero to be taken the moment the scale's output meets the criteria for range and motion band. Setting this value to ½ second will cause the controller to seek acceptable readings within the motion band for ½ second before updating the zero.

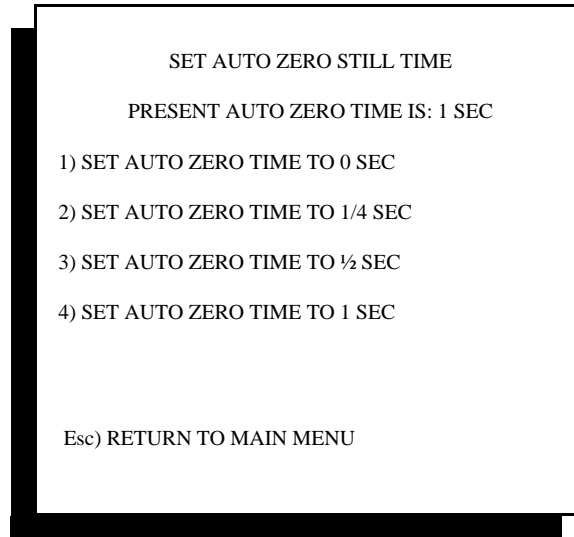

Setting Auto Zero Time

5.2.4 Test Routines

Many times it may be advantageous to manually confirm the operation of any or all of the Checkweigher's Inputs and/or Outputs, and printer functions. This menu selection allows for several types of tests:

1. Test 473 I/O Card
2. Test 477 I/O Card
3. Test Printer/Remote Port

5.2.4.1 473 I/O Test

"Test 473 I/O Card" provides two distinctly different types of test procedures:

- #1 473 Card Rotating "ON" Test
- #1 473 Keyboard "ON" Test

The "Rotating" test allows each output to be turned on for one (1) second. When invoked, this test will automatically turn on output #1 for 1 second, turn it off for one (1) second, then turn on output #2 for 1 second, etc. The Checkweigher controller will remain in this test until it is stopped by exiting from the screen. This test also displays a set of eight "0"s on the screen, each representing one of the eight Inputs. Applying 110 VAC (or 24 VDC if a DC I/O card) through a switch or contact will change the corresponding Input's "0" to a "1". This confirms that the Input circuitry and the Checkweigher's program are responding correctly.

The "Keyboard" test allows each output to be turned on individually by pressing a corresponding number key on the front panel. If output #1 is to be turned on, simply press the #1 key on the Checkweigher's front panel. To turn the output off, press the "0" key on the Checkweigher controller front panel. As with the "rotating" test, the "Keyboard" test allows for testing of each Input.

5.2.4.2 477 I/O Test

If your system is equipped with the #477 Traffic Control Card, you can test both the "Leading" and "Trailing" unit cards for I/O and serial communication function. An address jumper in the bottom three terminals of the 12 pin connector located at the top of the #477 card sets this card to either a "Leading" or "Trailing" card. A "Leading" card will have NO jumper. A "Trailing" card will have a jumper from pin 10 to pin 12. Entering into this menu selection will present a screen with several choices:

1. Input/Output Test
2. Local Loop Back UART Test
3. Remote Loop Back UART Test

5.2.4.2.1 I/O Test

Up to version 7.2 of the Checkweigher program, the available 110 VAC inputs and outputs on the #477 are not enabled. This test is provided, but does not need to be conducted unless your specific program uses these I/O. This test operates similar to the 473 "rotating" test described above. Each of the four (4) outputs on the 477 card will be turned on for 1 second, turned off, and then the next output will turn on for 1 second. Each output can be tested with a volt meter to confirm proper operation. As with the 473's test, the 477 also displays "0"'s for each of the four (4) inputs. Driving each input high will turn the displayed "0" to a "1".

5.2.4.2.2 Local Loop Back Test

This test checks the operation of both the transmit and receive ports on the 477 card. This test is for a single 477 card. Testing for two 477 cards in separate controllers is described below in 5.2.4.2.3. If the card is configured for RS-232 communications, (typically for interface to a computer or remote PLC device) connect pin 2 to pin 3 to perform the loop back test.

If the card is configured for RS-422 communications, (typically used for longer distance communications and/or use with StatPak-PC) connect Pin 1 to Pin 3, and Pin 2 to Pin 4.

When the test is started, the display will show transmission of a character, starting with "A" and incrementing thru "Z". Next to this display it will provide a visual indication that the character has been received by displaying the same character. If this operates properly, then the transmitting and receiving ports on the card are functioning properly.

5.2.4.2.3 Remote Loop Back Test

The remote loop back test is dedicated to testing two 477 cards used in connected Checkweigher controllers, with each card residing in separate Checkweigher controllers.

The test must be turned on in both units for it to function properly.

The Leading unit controller will transmit a character starting with "A", and will transmit a new character every 1 second. The Trailing unit controller will echo this character if it properly receives it, and will then transmit a character back to the Leading Unit controller. If both units display updates to both transmission and reception of characters, the cards are functioning properly.

5.2.4.3 Test Printer/Remote Port

Each Checkweigher controller is provided with two serial ports located on the face of the #470 CPU card. One port is labeled "PRINTER", and the other is labeled "REMOTE".

The printer port is disabled unless the optional STPR statistical production reporting packaged has been purchased. If this port is active, two tests are enabled to allow confirmation of operation of the port and the printer.

The remote port is always active, and transmits weight data in either a continuous (stream) or one-shot (ticket) mode.

Three tests are provided to exercise the optional printer port, optional printer, and remote port. These tests are:

1. Printer On/Off Line Test
2. Print Test String
3. Remote Test

The printer On/Off line test allows for visual verification of the printer's status. The four (4) conductor printer cable between the Checkweigher controller's "PRINTER" port and the 52394 serial converter enclosure included with the STPR printer package performs two functions. First, it establishes hardware hand shaking between the printer and the Checkweigher controller. If the Checkweigher controller does not "see" the printer, then it will not transmit data. For the printer to be On Line, it must drive the interface on the Checkweigher's PRINTER port low.

If the printer is On Line, the Checkweigher controller's display will indicate that the printer is On Line. If the printer is turned off, or is turned Off Line, or if serial communications with the printer are not properly established, the Checkweigher controller's display will indicate that the printer is Off Line. See Appendix A below for information on testing the serial converter included with the optional STPR printer package.

Once you have verification that hardware hand shaking is established and properly functioning, you can invoke test #2 and transmit a test string to the printer. When this test is enabled, the string "The Quick Brown Fox.....". This string will print continuously until the test is turned off or the printer is turned Off Line.

The remote test will transmit a string of weight data to a remote display or computer port. The remote port does not use hardware hand shaking, so there is no means of testing the integrity of the serial link other than by transmission of data. This signal is a 20mA current loop serial port (not analog), and therefore generates differing voltages when transmitting.

To electrically test this port to confirm transmission, first confirm that a jumper between terminals #4 and #7 is in place, the plus (+) signal is wired to terminal #1, and the minus (-) signal is wired to terminal #3. Now place a digital volt meter on mA (milliAmps), and place the plus lead on terminal #1 of the REMOTE port. Place the common lead on terminal #3 of the REMOTE port. When the line is idle, the mA reading should be 19 to 20mA nominal. When data is transmitted, the mA reading will drop to 15mA. The line should pulsate between these two readings as data is transmitted.

5.2.5 Set Language

Menu structures within the Checkweigher controller are English by default. Selecting Spanish from this menu setting will change all controller menus to Spanish. Weights, timer settings, and other system variables are unchanged when selecting either language. The following screen is displayed upon entering this variable:

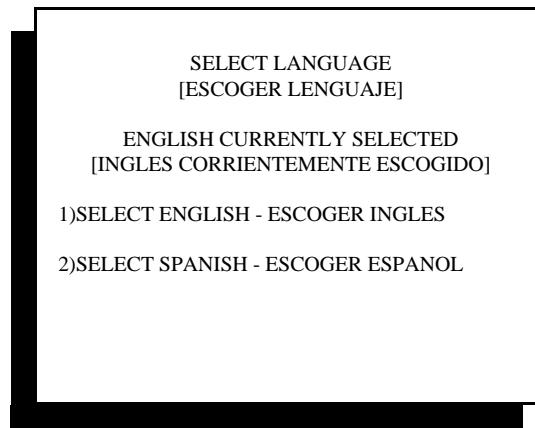

Selecting Language

A controller set to Spanish can be easily changed back to English to perform troubleshooting or other maintenance, and then switched back to Spanish when ready to operate.

5.2.6 Set Motor Parameters (Sonic 350 Only)

The Sonic 350 Checkweigher uses Servo style motors to operate each conveyor. These motors can be configured to operate the conveyors at speeds ranging from 25 to 200 feet per minute, and have different acceleration rates for ramping up and down the conveyors from a stop to full speed and back again. This configuration menu also allows for a selection of two styles of servo motor and the direction of travel for the motors:

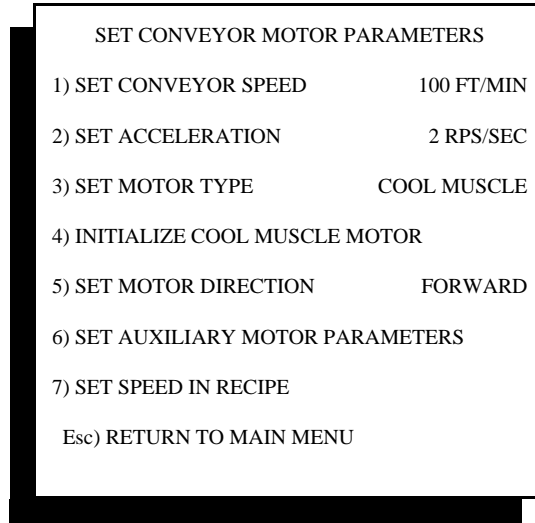

Setting Motor Parameters

5.2.6.1 Set Conveyor Speed

The Sonic 350 Checkweigher can be set to run at different speeds to accommodate changes in package length and production rates. Entering into this menu item will display a screen for entry of the new conveyor speed in Feet Per Minute. A value from 25 to 200 can be entered.

A minimum amount of weigh time is required for a specific package length. Please contact the factory for assistance when selecting a speed for your particular package or packages.

5.2.6.2 Set Acceleration

The Sonic 350 Checkweigher’s conveyors can be set to either slowly or quickly ramp up to the desired conveyor speed by adjusting this setting. The lower this setting’s value, the slower the conveyor will start and the longer the ramp will take to reach your specified conveyor speed. Applications for tall or top-heavy products will use a lower setting, while low-profile or wide-based packages can be accelerated much more quickly.

5.2.6.3 Set Motor Type

Two different motor manufacturers have been used since the Sonic 350 was introduced several years ago. The motor used from 2003 to present is called a “Cool Muscle” style motor. The predecessor was called a “Quick Silver” style motor. The default for this setting is “Cool Muscle”.

5.2.6.4 Initializing The Cool Muscle Motor

If the Cool Muscle style servo motor is being replaced or has set for an extended period of time without power applied, it may be necessary to re-initialize the motor. This configuration setting transmits a list of commands to the motor to dictate its behavior prior to use.

5.2.6.5 Set Motor Direction

The servo motors used on the Sonic 350 Checkweigher can be run either forward (clockwise) or reverse (counter-clockwise). This setting is relative to the motor mounting (left or right) for the conveyor. Our default is a right-hand motor mount, which requires the Forward setting.

5.2.6.6 Set Auxiliary Motor Parameters

For special checkweigher configurations, it is possible to have either a dual Sonic 350; using two scale conveyors side-by-side, or a 4-belt checkweigher system with the in-feed conveyor running at a different speed than the other conveyors. In these and other special cases, it is advantageous to have separate control over one or more motors. In the case of the dual Sonic 350, motors for the dual scale conveyors must be on opposite sides of the conveyor frames to accommodate close spacing between the conveyors. One motor must run “forward” while the other runs “reverse”.

This configuration setting lets the user configure the auxiliary conveyor motor as required for the application. The following screen is displayed when this setting is selected:

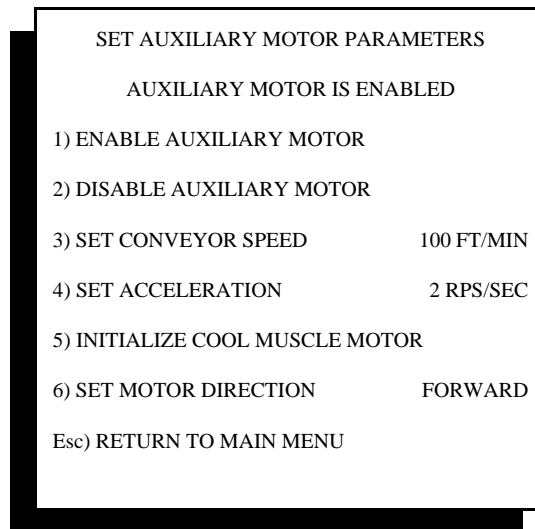

Auxiliary Motor Parameters

If the auxiliary motor is being used, enable the motor by selecting item #1 from the above menu. Settings and their descriptions for this motor’s configuration can be found above in items 5.2.6.1 through 5.2.6.5.

Electrical connection to this motor is handled slightly differently than for other Sonic 350 motors. Please refer to system drawings at the back of this manual.

5.2.6.7 Set Speed in Recipe

Motor speed and acceleration can be set either through this configuration menu, or can be set with each product recipe entered in the checkweigher. Recipes contain Target weights and reject limits for each product type or weight run, and speed may vary based upon the product length and production rate. Setting this value to “Set Speed In Recipe” will display conveyor speed settings and reject timer settings, as described in Chapter 4, Section 4.3.1

5.2.7 Configure Reject Outputs

This menu setting allows the default configuration of the reject output to be changed to one of several alternate configurations. The default configuration for the Checkweigher is a single reject signal for under-weight, over-weight and metal detector rejected product.

NOTE: If reject outputs are reconfigured, please return to Main Menu #4 (Set time, date, and reject times) to modify delay and duration timers for each separate output.

Entering into this menu selection will allow you to configure the controller for operation of separate over-weight and metal detector outputs, as described in the following screen.

NOTE: The Checkweigher can be configured as a dual system, operating two weigh station conveyors from a single controller. When this configuration is used, a separate set of reject outputs reside on a separate #473 or #573 I/O card for the second scale. Menus below show a reject actuating a specific output with the second scale's output in parenthesis.

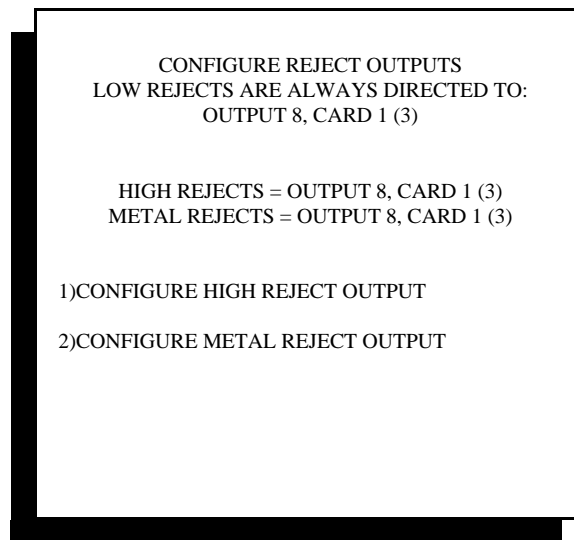

Reject Output Configuration

To configure over-weight packages for reject by a separate output, select item #1 from the menu above. A new screen will appear, as shown below:

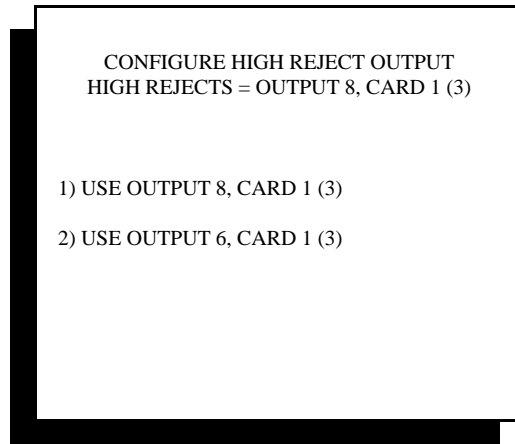

Setting High Reject Output

If a metal detector is interfaced to the Checkweigher, a separate output can be assigned for a third, or combination of:

- Metal reject + Under-weight rejected from same device
- Metal reject + Over-weight rejected from same device
- Metal reject on its own device

From the reject configuration screen, shown on the previous page, select configure metal reject. The following screen will appear:

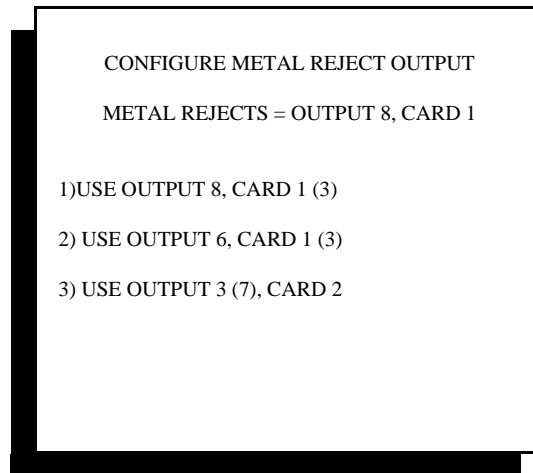

Setting Metal Reject Output

Please note if output #3 on Card #2 is selected, a second #473 card must be installed in the Checkweigher controller's card rack to accept this input.

Once all changes to the configuration menu have been made, simply hit the **Esc** key on the controller's front panel to return to the Main Menu. Changes made will take immediate affect.

5.2.8 Product Load Options

This menu choice only appears if the #477 Serial Communications Card (Traffic Control Card) or #483 Serial Card is installed and properly configured in the controller rack. If this card is not present, this menu item will show “Not Used”. See Appendix A for information on setting and use of this option.

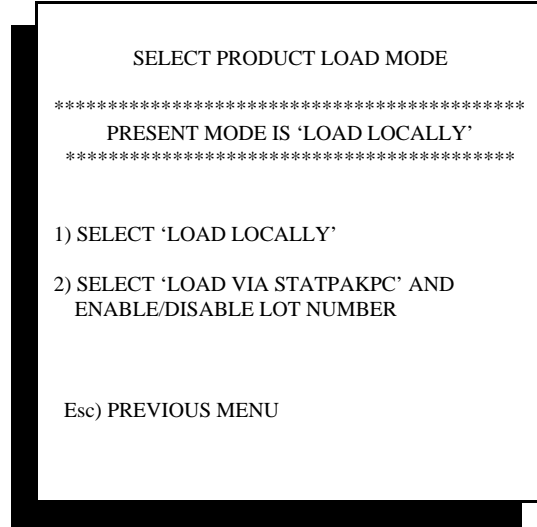

Product Load Options

5.2.8.1 Load Locally Setting

This is the default setting for the checkweigher, and allows for recipes to be created, stored and called (loaded) from the controller.

5.2.8.2 Load Via StatPak-PC

StatPak-PC is a data logging and reporting software exclusively available from Thompson Scale Company and our distributors. This program resides in the user’s PC and connects in real-time to the checkweigher via either serial or Ethernet connections.

When this mode is selected, product recipes are stored remotely in the StatPak-PC database, not in the checkweigher memory. An operator selects the “(P) PRODUCT LOAD” option from the checkweigher Run screen, and the checkweigher program automatically queries StatPak-PC for information on the recipe being requested by the operator

In this mode the user can also enable or disable the use of a lot number to associate with each production run. When enabled, the lot number function will force the operator to enter a lot number before the loading of recipe information is complete. This lot number is then forever associated with the weight data gathered for that particular production run.

5.2.9 Batch Report Enable/Disable

This menu choice only appears if the Checkweigher EPROM has been programmed to contain this option. If available, it replaces the STPR printer option with the ability to print a ticket of each unit weight and summary of data for pallet or lot runs, and can be used as a shipping ticket. See Appendix B for information on setting and use of this option.

5.2.10 “P” Set Photo-eye Configuration

The Checkweigher is designed to weigh product crossing the scale based solely upon the output of the weigh station load cell. However, special circumstance may require the use of one or two photo-eyes on the weigh station to assist with higher production rate requirements or to detect a number of other events.

In addition, certain applications require these photo-eyes to respond very quickly, such as with a high production rate checkweigher, or may require some degree of filtering to accommodate special products or container surfaces.

Upon entering this menu, the user is presented with five (5) options for photo-eyes:

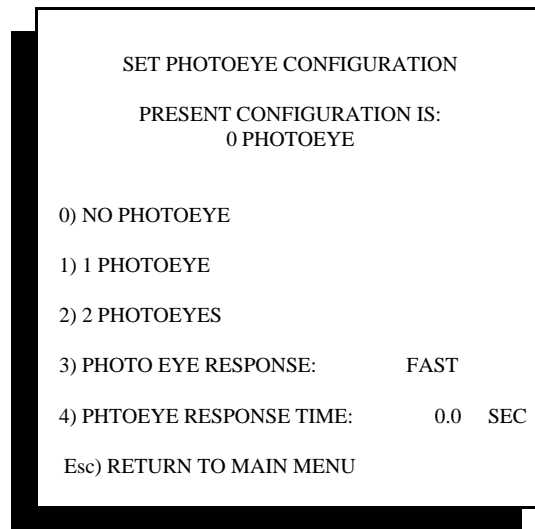

Selecting Optional Photo-Eyes

Selecting “0” or no photo-eye is the default for the Checkweigher. This allows the Checkweigher to weigh packages upon load cell output alone. The option for “1” photo-eye is used for two purposes:

5.2.10.1 Early Weight Terminate Photo-eye

1 Photo-eye Option: The early weight terminate photo-eye option is used in applications where product spacing may be an issue. The standard Checkweigher, weighing product based only on load cell output, must see the leading edge of the package exit the weigh station conveyor before terminating the weighment of that package. This requires that the next package cannot begin onto the weigh station till approximately 1/4 of the 1st package is off the weigh station.

The early weight terminate photo-eye is mounted at the very end of the out-feed end of the weigh station conveyor, past the end of the roller, looking between the gap of the Checkweigher and the next down-stream conveyor. When the leading edge of the package crosses the weigh station conveyor and blocks this photo-eye, an input within the Checkweigher controller is driven “high”, instantly causing the weighment of this package to be terminated. At that instant, a new package may begin onto the weigh station.

While the 1st package is exiting the weigh station conveyor, and the early weight terminate photo-eye is blocked by the package, weight samples are NOT being collected on the 2nd package. Once the 1st package fully clears the weigh station conveyor and the photo-eye becomes clear, weight data is collected and stored on the 2nd package.

It is very important that the early weight terminate photo-eye is properly positioned, looking across the gap between the out-feed end of the weigh station and the next conveyor. Placing this photo-eye too far back onto the Checkweigher weigh station may cause invalid weight data to be collected since the 1st package will not be fully off the weigh station conveyor when the photo-eye clears. This may cause erratic weight readings on the 2nd package.

5.2.10.2 Empty Package Detection

Many automated packaging lines experience problems with empty bags or boxes being accidentally dropped onto the conveyor equipment at the filling or packing station. These empty items can become entangled in palletizing or unitizing systems, cause problems with false triggering photo-eyes used on the conveyor line.

Using the early weight terminate photo-eye in a slightly different way can eliminate these empty bags from getting into the system. Although the Checkweigher is very sensitive, and yields highly accurate weights on filled bags, it cannot detect a weight less than 4% of the calibration weight crossing the weigh station.

If the Checkweigher program detects the presence of weight on the weigh station conveyor, and the empty package detection photo-eye beam is blocked by the leading edge of the package, the package is properly weighed. If however the program does not detect the presence of weight and the photo-eye becomes blocked, it is assumed that it is an empty package. When an empty package is detected, the standard timing and output for a normal rejected package is used.

5.2.10.3 Conveyor Jam Condition

The final use of this photo-eye is in detection of a stalled or jammed weigh station conveyor. Circumstances, such as a stalled conveyor motor, product jam on the conveyor line, or unexpected stoppage of the conveyor line can be detected by using the early weight terminate photo-eye.

If the photo-eye becomes blocked for more than 5.0 seconds, an alarm is actuated within the Checkweigher controller. This alarm cycles outputs #1, #2 & #3 on the 1st I/O card, turning all of these outputs on for one (1) second, then off for one (1) second. The end user or system integrator can take any or all of these outputs into the system PLC controls and detect the alarm condition, then actuate an alarm or use other means to alert an operator to the condition.

The option for using two photo-eyes also has several possible functions:

5.2.10.4 High-Rate Photo-eyes

2 Photo-eye Option: When two (2) photo-eyes are used on the Checkweigher weigh station, one is positioned as described above for the early weight terminate photo-eye, and the other is positioned at the In-Feed end of the weigh station conveyor, “looking” across the gap between the end of the conveyor feeding the weigh station conveyor and the in-feed end of the weigh station conveyor.

When a package enters the weigh station conveyor, the photo-eye at the in-feed end (we’ll call it photo-eye “B”) becomes blocked by the package. Once the trailing edge of the package clears photo-eye “B”, the Checkweigher controller begins collecting weight data on the package.

When the leading edge of the package blocks the photo-eye at the out-feed end (we’ll call it photo-eye “A”) the weighment cycle is terminated. The advantage of this arrangement allows for much faster weighment cycles than typically required, and allows bags to be significantly closer together. Once photo-eye “A” becomes blocked and the weighment cycle is terminated, a 2nd package can begin entering the weigh station without affecting the weight of the 1st package. Conveyors can be run faster, and product can be spaced more closely than in normal applications.

5.2.10.5 Detecting Packages Too Close Together

As described above, it is possible to configure the weigh station conveyor so that maximum production rates and minimal product spacing can be realized. However, one of the events that may occur in this type of production environment is that packages can sometimes become too closely spaced.

Using the two photo-eye arrangement detailed above, the Checkweigher can determine if product is too closely spaced. If the “B” photo-eye becomes blocked and then cleared as a product crosses in front of this eye, and then becomes blocked again before photo-eye “A” has terminated weight on the 1st package, an error is created.

Since two packages on the weigh station conveyor could be as close as touching, or as far as just barely too close, they cannot be rejected or handled normally. The Checkweigher generates a separate alarm output specifically for this fault condition. Output #5 on I/O card number 2 (a purchased option not included in the standard system) is actuated the instant the fault is detected, and remains on for one (1) second. An error message of “product too close” is also displayed on the main checkweigh screen.

The auxiliary output #5 on card #2 should be used in conjunction with the standard reject output(s) that would actuate if a single bag were to reject due to weight. If this is not done, it is likely that the checkweigher will actuate the standard reject output(s) and not accommodate the second bag that actually caused the error and reject.

5.2.10.5.1 Enable or Disable Bags Too Close Reject

Within the photo-eye configuration screen, select item #2 “2 Photo-eyes”. The following screen is displayed:

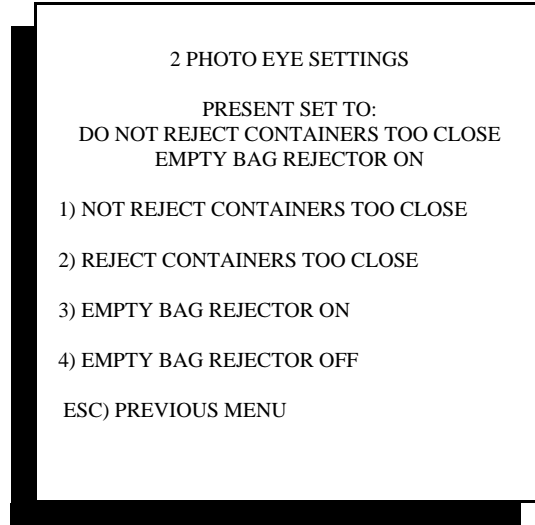

Photo-Eye Reject Methods

Selecting item #1 “Not reject containers too close” will ignore both the weight and rejection of two items detected by the EWT2 photo-eyes as being too close together on the scale. While this menu choice will intentionally allow un-weighed packages to pass through the checkweigher, it does eliminate potential problems from improperly spaced bags passing through your reject system. Please note that package weights are not calculated and package totals are not updated with information from these packages.

Selecting item #2 “Reject containers too close” will allow the checkweigher to weigh (and mis-weigh) the packages that are too close, and will actuate the reject and auxiliary signal for removal of these packages. This is typically used in an application where it is essential that each package weight is verified prior to shipment.

Select item #3 “Empty bag rejector on” enables the checkweigher’s ability to detect and reject an empty package or container entering the scale conveyor. The checkweigher’s normal weighing algorithm may not necessarily detect an empty package by its weight alone. Additionally, conflicting information may be generated by a package or bag with a loose or floppy flap or tail on the leading or trailing edge of the package; such as an open-top box with a plastic bag liner, with the trailing edge of the box/liner blocking and unblocking the photo-eye several times as the container passes in front of the photo-eye.

Enabling this feature would be useful in cases where empty containers or packages may cross the scale and need to be rejected.

Selecting item #4 “Empty bag rejector off” will disable this same feature.

5.2.10.6 Photo-eye Response Type

Under most normal conditions, either of the photo-eyes used on the checkweigher will become blocked and then cleared as the package crosses in front of the eye. However, some package types may have either a shape or particular type of reflective surface, or a leading edge or trailing edge “tail” of material (such as from a FFS type bag) that will cause the photo-eye to false-register (block/clear/block....) as the package passes before the photo-eye.

If the package is moving quickly, at rates of 70 to 400 packages per minute, or if the package is an item like a box, bag or pouch with clearly defined ends and a consistent surface, the “FAST” response selection for the photo-eyes should be selected. This is the default for the checkweigher. However, if the package type causes false triggering of the photo-eye or unreliable behavior of the photo-eye, select the “SLOW” response.

5.2.10.7 Photo-eye Response Time

If the “SLOW” response type is selected, as described above in 5.2.10.7, a specified period of time must be set for the delay in the photo-eye signal. This delay is a trailing edge delay. When the photo-eye first becomes blocked, this delay will set how long the photo-eye’s signal must be off before the controller will recognize and respond to that change. If a FFS bag or pouch has a “tail” of loose material after the seal, and it causes the photo-eye to make and break several times within one second, then setting this time value to 0.5 second or longer will require the photo-eye to become blocked and cleared for 0.5 second before the checkweigher controller recognizes the input turning off.

This value can be set from 0.0 to 2.5 seconds.

5.2.11 “R” Enable or Disable Reject Confirmation

A photo-eye can be added at the in-feed of the conveyor or table that accepts rejected packages. If the Checkweigher issues a reject signal, and the accumulation conveyor or table photo-eye does not become momentarily blocked by the package within 1 second, an alarm status signal will be generated by the Checkweigher controller. Outputs #1 through #5 on card #1 (default card) will be turned on for one (1) second, then off for one (1) second, and will continue to do so until an operator acknowledges the alarm condition at the Checkweigher controller.

An error message will also display on the Checkweigher’s LCD display. This error will remain in place until the operator clears the error.

This same photo-eye will detect the reject accumulation conveyor or table becoming full. If the reject confirmation photo-eye (same photo-eye as described in the above paragraph) becomes blocked for more than five (5) seconds, this will cause the Checkweigher controller to initiate an alarm condition. Outputs #1 through #5 will be turned on and off in one (1) second intervals until the operator clears the condition and acknowledges the alarm on the Checkweigher controller front panel.

5.2.12 “T” Trend Alarm or Overweight Alarm Output

This configuration setting actually contains three possible variables; Trend Alarm, Overweight Alarm and Weighment Pulse. The variable selected disables the other two variables. That is to say, if you select Weighment Pulse, you cannot also have Trend Alarm and Overweight Alarm. Each variable is described below:

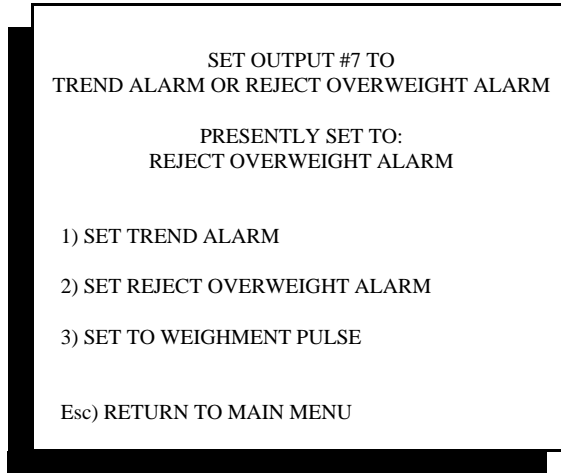

Selecting Trend/Overweight Alarm

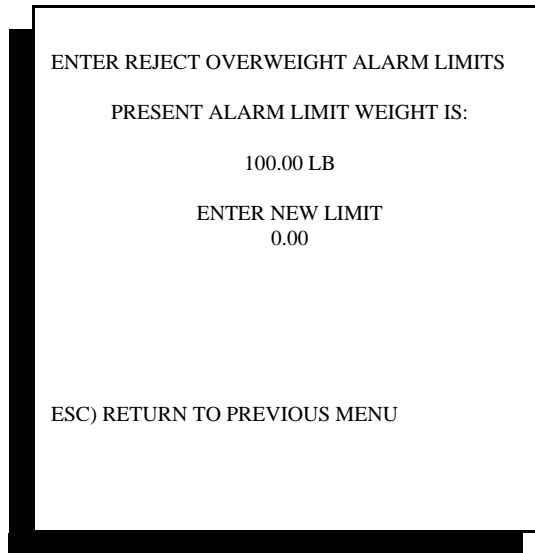

Overweight Limit Setting

Trend Alarm is the default setting for the Checkweigher controller. Main Menu item #6 “Trend Alarm” is active when the Checkweigher is shipped. See Chapter 4 for information on setting Trend Alarm functions. The Trend Alarm will actuate an alarm output when a set consecutive number of rejects occur on the production line. This feature can alarm only on consecutive under-weight rejects, only on consecutive over-weight rejects, or only on consecutive under and over-weight rejects. Additionally, for Checkweigher controllers provided with the optional STPR production reporting package, the trend alarm feature within the statistics menu is disabled.

Overweight Alarm, when enabled, will disable the Trend Alarm and access to Trend Alarm settings from the Main Menu. The Overweight Alarm monitors the total amount of rejected material and then actuates an alarm output when that amount is met or exceeded. This is very useful for applications where rejected raw material is fed back into a blending or filling operation, and only a specific amount of re-worked or recycled material is allowed within the batch.

When the Reject Overweight Alarm option is selected, a new menu item appears in the Main Menu item #4 “Set Time/Date Reject Time. Enter into this menu and access to the Overweight Alarm will be available:

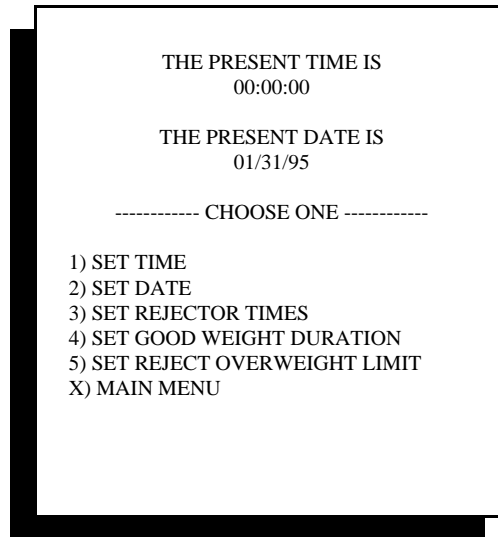

Main Menu #4

Selecting item #5 from this menu will display the following screen:

The Overweight Alarm Limit can be up to 99999.99, and will be displayed in whatever weight conversion is currently in use for the current recipe.

Once this value is set, the checkweigher program will monitor the accumulated reject weight value for the current production run. When that reject weight value meets or exceeds the value entered here, Output #7 on I/O card #1 will be turned On for one (1) second, then Off for one (1) second. This output will continue to actuate until the operator presses a key on the 4693 controller’s keyboard.

The current weight totals **MUST BE CLEARED** from the “Run Checkweigher” screen before the Overweight Alarm will operate again. The program only monitors the accumulated reject weight, and only activates the alarm when this value is reached.

Weighment Pulse is the third possible choice for this output configuration. When selected, a new menu item appears in the Main Menu #4 “Set Time/Date and Reject Time”, as shown below:

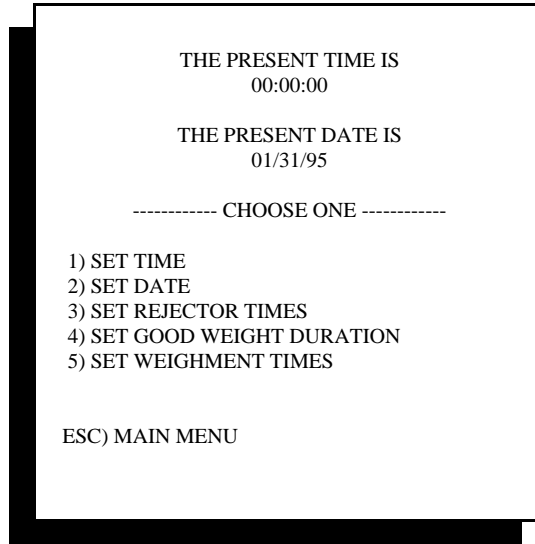

Main Menu #4

When “Set Weighment Times” is selected, the following screen is displayed:

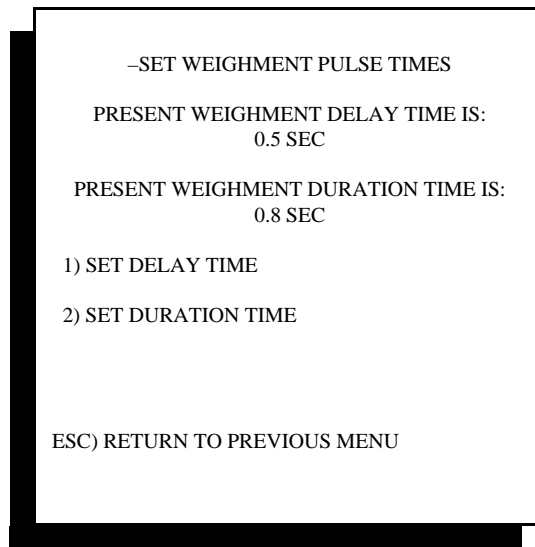

Weighment Pulse Option

Delay time for the weighment pulse can be set in tenths of a second, up to 25.0 seconds, and is used to delay the output of this signal until the weighed package reaches a specific point down-stream of the checkweigher conveyor. Please note that a maximum of eight (8) packages can be held in the weighment pulse cue.

The duration time is also set in tenths of a second, and limited to 25.0 seconds. This actuates output #7 on I/O card #1.

5.2.13 “A” Averaging Checkweight Function

Special applications occur that require a slightly different method of tracking and weighing product. The 4693 Checkweigher controller contains an averaging function that gathers weight values, averages these values and then adjusts the Target weight to meet the new average. This is useful in applications where filling is placed within a pie or sponge cake, or when a resin’s bulk density changes during process due to temperature or humidity. Although the weight values may change for the completed unit crossing the scale, it does not always mean that unit weight is out of specification.

Upon selecting “A” Averaging Checkweight Function from the configuration screen, the following sub-menu will appear:

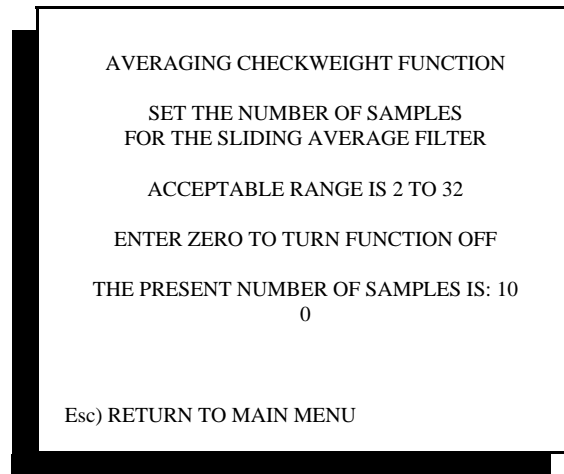

Setting Avg Ckwr Function Variable

Upon setting this variable to a value greater than 0, the checkweigher controller will add a new variable to the product recipe menu (Main Menu item #5 - Select/Edit Product - Target Weight, reject limits, etc.). An example is shown below:

1) HIGH REJECT	5.00 LB
2) HIGH PASS	4.55 LB
3) TARGET WEIGHT	4.50 LB
4) LOW PASS	4.48 LB
5) LOW REJECT	4.45 LB
6) CONTAINER WEIGHT	0.02 LB
7) SET WEIGHT AVERAGING VARIABLES	
Esc) RETURN TO MAIN MENU	

Product Recipe & Wt Averaging

Entering into menu item #7 will display the following screen:

SET WEIGHT AVERAGE REJECT LIMITS	
1) SET OVER AVERAGE LIMIT	
2) SET UNDER AVERAGE LIMIT	
Esc) RETURN TO MAIN MENU	

Setting Averaging Wt. Limits

Selecting either will offer a corresponding screen where the amount of weight error is to be entered. Unlike the product recipe, where an actual fixed value (4.45 lbs.) is entered, the actual amount of error is required in this screen; 0.05 lb. A positive error is entered for OVER weight, and a negative error is entered for UNDER weight.

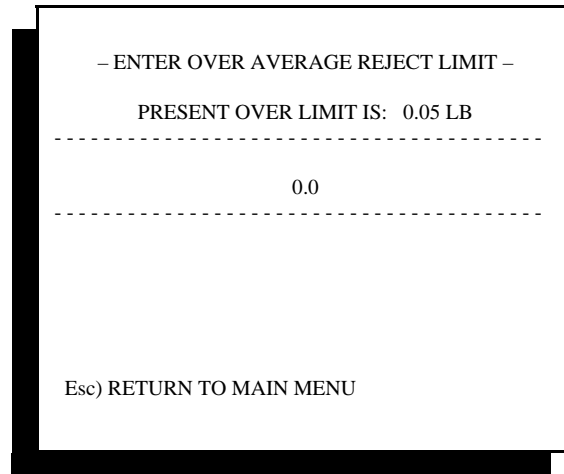

Entering Average Wt. Limits

Once the specified number of containers cross the scale to fill the register for the sample selected above, the checkweigher will automatically average these samples and determine the new “Target” weight. This value will be displayed in the “Run Checkweigher” screen. The reject limits will be compared to each weight crossing the checkweigher, with reject outputs being operated as with the standard program.

Additionally, this averaging program discards weight values that are more than 10% from the average Target value. These items will be weighed and rejected, but their values will not be included in the sample set for determining the average Target. This is done to avoid problems caused by an empty or near-empty container, or two containers from crossing the checkweigher and their invalid weights skewing the overall population.

5.2.14 “F” Weight Feedback Function

Feedback is a function of the checkweigher that averages weights crossing the checkweigher and then returns an error value back to the upstream filling, counting or slicing machinery controls. This is of particular use with volumetric fillers, such as liquid or powder/granular auger fillers.

Please see Chapter 8, Section 8.2 for more information on this feature.

Three variations of closed-loop feedback are available with the Checkweigher. Each are shown in the screen displayed when “F” is selected from the configuration menu:

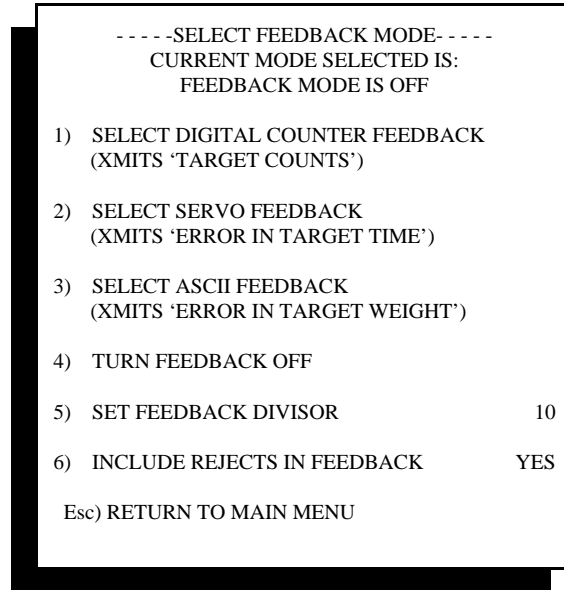

Feedback Functions

The **digital counter feedback** is for use with filling machinery that fills by counts. This includes a number of vertical auger or impeller type fillers.

Servo feedback is normally used with a volumetric filler that works off a set position or time. A plus or minus DC voltage is sent to the servo to adjust its position or fill time.

Finally, the **ASCII feedback** sends a serial message containing the positive or negative error from the target weight. Many variations of this feedback loop are available, and should be discussed with our factory technical or engineering departments to ensure selection of the best fit for your application.

Other settings available in this menu include:

4) **Turn Feedback Off.** If feedback has been enabled (selecting menu choices 1, 2 or 3), and you wish to turn off the feedback for testing or to disable the feedback, select this item.

5) **Set Pulse Feedback Weight** sets the amount of correction is induced per correction. If, for example, the checkweigher is set to operate with no decimal, and this value is set to a value of one (1), the resulting error correction will be in increments of 1. That is to say that if the target weight were 50g, the minimum correction would be 1g, if this value were set to 1.

If the decimal point were set to 1 (0.0), and the target were 50.0g, the minimum correction would be 0.1g, if this value were set to 1.

6) **Include Rejects In Feedback.** This menu choice allows or disables inclusion of rejected weights from the closed-loop feedback.

If rejects are allowed (the default setting), then all weight values outside of low pass and high pass will be used to determine the amount of correction to induce.

If rejects are not allowed, then only weight values falling between low pass and low reject, and between high pass and high reject will be used. That is to say no weights that are considered as “good” and no weights considered as “reject” will be included in the calculation for feedback.

5.2.15 “N” Next Menu

Selecting this item will display a 3rd configuration screen with settings, as shown below:

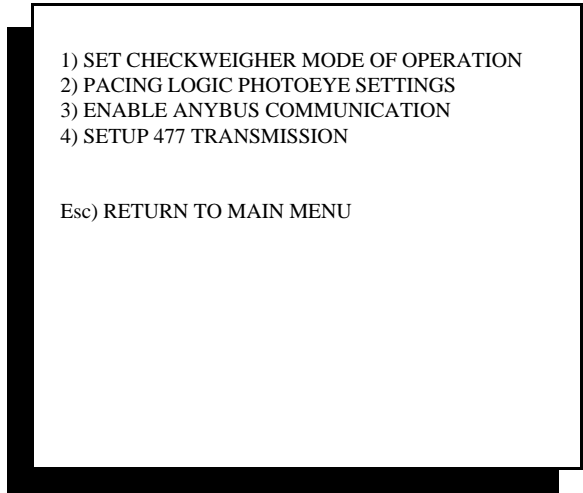

Configuration Menu #3

5.3 Third-Level Configuration Screen

Each item is described below:

5.3.1 Set Checkweigher Mode Of Operation

This configuration setting contains three choices;

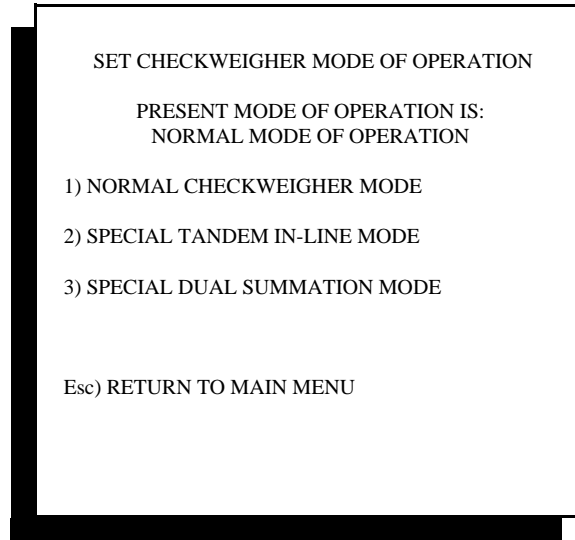

Checkweigher Mode Screen

5.3.1.1 Normal Checkweigher Mode

The Normal Checkweigher Mode is the default setting, and is used for virtually all checkweighers, including dual or multiple lane checkweighers.

5.3.1.2 Tandem Checkweigher Mode

The Tandem Checkweigher Mode enables the 4693 controller to operate two scale conveyors, one directly after another, to provide a weighing solution for vastly different products run on the same production line. For example, a package measuring only a few inches long would need to be run on a short scale conveyor to allow for reasonable conveyor speeds and to meet the high-rate production needs for this package.

Additionally, this same production line may run a long package that is actually as long or longer than the short scale conveyor. A second scale conveyor would be added, directly after the first, that would accommodate the longer package. Normally Thompson Scale can configure a single scale conveyor to meet production needs for the longest and shortest package and accommodate the highest production rate. Our Tandem In-Line Checkweigher is used in those extreme cases where a single conveyor cannot address the application.

WARNING: To use this feature, the checkweighers must have a photo-eye at the in-feed end and exit end of BOTH conveyors, AND must have enabled as described in Section 5.2.10, above.

5.3.1.3 Dual Summation Mode

In the dual summation mode the checkweigher must be configured as a dual checkweigher, with two scale conveyors residing parallel to one another. This mode is used to weigh a large package crossing both scale conveyors, summing the output of both scales to create a single weight output.

5.3.2 Pacing Logic Photoeye Settings

Logic in the checkweigher controls is capable of automatically pacing packages across the scale conveyor, ensuring that only one package crosses the scale at a time. ***This feature is not recommended for applications running in excess of 75 fpm and/or more than 40 packages per minute.***

Referencing Section 5.2.10, above, the configuration for photo-eyes should be set to 2 photo-eyes; one located at the in-feed of the scale conveyor and the other located at the out-feed of the scale conveyor. A third photo-eye, mounted near the discharge end of the conveyor before the scale conveyor can be used to monitor and automatically pace packages to the scale.

The pacing conveyor photo-eye should be placed approximately 3" from the out-feed end of the pacing conveyor, with the output of the photo-eye tied to the Checkweigher controller's #2 I/O card input #3. (See electrical drawings at the back of this manual) When this photo-eye is blocked by a package ready to exit from the pacing conveyor, the input will be driven high. Logic within the checkweigher controller will monitor the photo-eyes and start and stop the conveyor accordingly.

There are several methods that can be used to set the pacing method. The following configuration screen displays these methods:

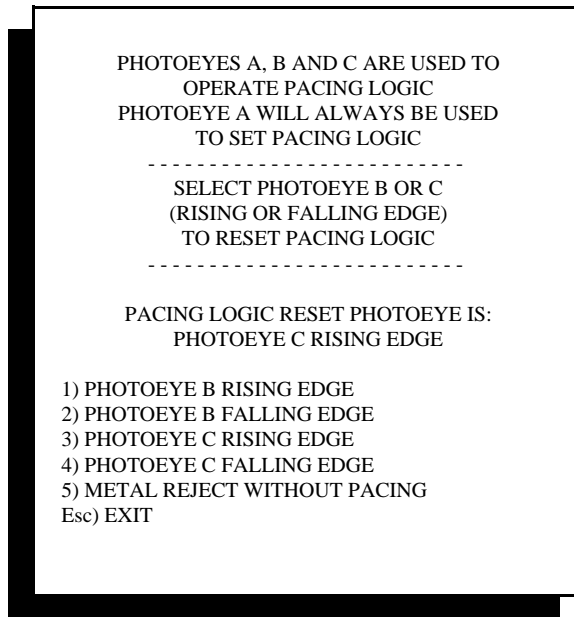

Pacing Logic Settings

Photo-eye "A" is the eye located on the pacing conveyor. Photo-eye "B" is at the in-feed of the scale conveyor, and "C" is at the exit end of the scale conveyor. The default configuration is for Photo-eye C, rising edge.

We define a rising edge as a package's leading edge blocking a photo-eye. A falling edge would be the tail end of the package clearing the photo-eye.

Different circumstances call for using different methods for releasing packages from the pacing conveyor. Although the default configuration is rising edge of photo-eye “C”, the length of the package and length of the scale conveyor may dictate using the falling edge of “B” to get the proper gap between packages.

Please consult with the factory for assistance on setting this feature.

5.3.3 Enable Anybus Communication

A purchase option is available to add bi-directional communication via an Ethernet IP (Allen-Bradley proprietary) port. This port, consists of a serial communications port and a serial to EIP converter and power supply mounted to the back panel of the checkweigher controller. See Appendix E for information on data and use of this port.

Once the EIP converter has been added to the controller, it must be enabled via this menu setting.

5.3.4 Setup 477 Transmission

Our #477 serial communications card can be added to the checkweigher controller rack, and can be configured as either RS-232 (4-wire connection good for about 75 feet) or RS-422 (5-wire connection good for 1,200 feet).

By default this port transmits each package weight. Other fields can be added through this menu setting.

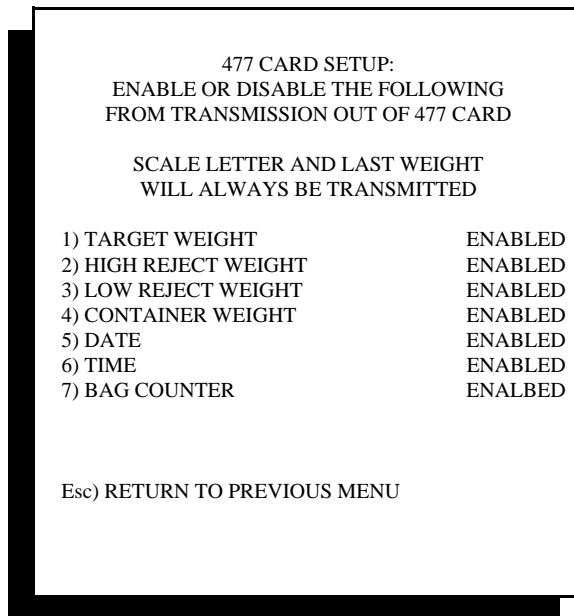

477 Serial Transmission Settings

Items #1 through #6 will transmit the corresponding value in the current recipe, along with the weight value. Item #7 will increment and transmit every time a package is weighed, and will clear to 0 whenever the user changes or re-loads the recipe.

**Archive your system's configuration on the following page. Once the checkweigher has been configured to meet your specific needs, write down each of these settings and place the information into this user's manual. If the system's CPU card ever requires replacement, this information will be invaluable to restoring your system quickly and accurately.

Checkweigher Configuration Sheet

Serial Number: _____

(inside controller, right side. 5 digit number with possible letter suffix, ex: 12150 or 12150A)

Sample Rate: _____

Filter Frequency: _____

Number of Filter Samples: _____ Decimal Point: _____ (0,1,2 or 3)

Remote Port Mode Of Operation: _____

Display Increments: lb:_____ kg:_____ oz:_____ g: _____

Auto Zero Settings: Motion Band:_____ Auto Zero Time:_____

Motor Parameters: Set in Configuration Menu or Each Recipe _____

Acceleration:_____ RPS/SEC Motor Direction:_____

Reject Configuration: _____

Product Load Option: (local/remote) _____

Number of Photo-eyes: _____

Reject Confirmation:_____ (Enabled or Disabled)

Trend Alarm:_____ (Trend or Over-weight Alarm)

Weight Averaging: _____(Enabled or Disabled)

Feedback: _____(Enabled or Disabled) Variable 1-6 _____

Checkweigh Mode of Operation: _____

Pacing Logic:_____ (Enabled or Disabled) Variable 1-5 _____

Ethernet IP: _____(Enabled or Disabled)

477 Transmission Settings: Variable 1-7 _____

Typical Heavy Duty Checkweigher Default Configuration Settings

EXIT Menu #1

Sample Rate	24
Filter Frequency	5
Number of Filter Samples	8
Maximum Product Number	02
#1 A-D Gain Number	200
Decimal Point	2
Display Slopes	Not Adjustable

Get The Next Menu (displays next sub-menu group)

Clear Audit Trail	Not Adjustable
Remote Port Mode Of Operation	Stream Mode
Display Increments	05
Auto Zero	
Motion Band	3
Still Time	0 Second
Language	English
Configure Reject Output	#8, Card #1 Low, High & Metal
Photo-eye Configuration	Application Dependent
Enable/Disable Reject Confirmation	Disable

Chapter 6

Trouble Shooting

This troubleshooting guide is broken into several categories, including mechanical and electrical description and general advice, and a troubleshooting guide with specific symptoms and suggestions.

6.1 Mechanical

When the Checkweigher suffers from erratic or inaccurate weights or improper actuation of outputs and reject devices, most of the root cause sources are mechanical in nature. Investigate the Checkweigher conveyors, framework and surrounding equipment first. Eliminate sources of vibration or interference first, and most likely you will find the cause of the problem you are experiencing.

Mechanical troubleshooting is mostly a matter of visually checking the conveyor system. Look for conveyors touching, erratic speed changes in the conveyor, worn belts or chains, loose or drive components and out of round end rolls on belt conveyors. Our end rolls are mechanically balanced to provide vibration-free operation. If the roll shaft is bent or damaged, the roll running out of round will induce vibration into the conveyor and scale.

Wind or air currents from open door ways, vents or fans will have an affect on the scale. The conveyor surface acts as a sail would on a sail boat. It's large surface area catches the wind, which is read as force. Use a wind screen to protect the scale and conveyor.

6.1.1 Weigh Station Conveyor Belts & Chain

Our line of heavy-duty and intermediate sized Checkweigher are provided with a weigh station conveyor using a high quality 2-ply PVC over Polyester cord conveyor belt with a V-guide vulcanized to the underside for positive tracking in the V-groove of the slider bed and pulleys. This belt should be run relatively loose. With the conveyor off and no product on the conveyor, it should be possible to lift the edge of the belt 3 " off the slider bed, between the head and tail pulleys. If the belt runs too loose, slippage may occur if product is stopped on the weigh station conveyor. If the belt is run too tight, damage will occur to the head and tail pulley bearings, and possibly bend the pulley shafts, making the pulleys run out of round, which of course would induce a tremendous amount of low frequency vibration.

The Thompson Scale 4693-RL Raise-Lower checkweigher for up-right bags uses a slightly different type of conveyor and belt, using a powered end roller that is crowned. The belt does not include a V-guide, but is a polyester cord type belt with a micro splice. Belt tension on this conveyor will be slightly greater than mentioned above, and should be sufficient to properly track the belt and manage transfer of the heaviest bagged product.

Our small package Checkweighers provided with belt conveyors use a 1-ply endless belt. If this belt becomes stretched or worn, it too can induce vibration and "noise" into the scale. This belt must be run tight enough to carry product across the conveyor yet loose enough not to induce undue wear to the head and tail roll bearings.

Thompson Scale's small package Checkweigher provided with parallel sets of drag chain to convey product must also be maintained properly and run loosely to allow for proper weights. If this chain becomes damaged or worn, the offending sections of the chain must be replaced immediately. If damaged or worn chain is used it will in turn damage the chain guide rails, causing further harm to accuracy and repeatability. The chain should be cleaned on a regular basis commensurate with the product and environment for the application.

6.1.2 Weigh Station Scale

The weigh station scale used with the heavy-duty and intermediate model Checkweighers is a flexure type scale system containing one (1) load cell. Although this component requires minimal attention, it should be noted that product build up or corrosion can affect performance. The scale is constructed of several parallel flexure plates tied back to a central location. These flexures should be kept free and clear of product for maximum performance. In applications where product dust or build up is a normal occurrence, the scale should be cleaned with low pressure air on a regular basis.

Our 4693-RL Raise-Lower checkweigher for up-right bags uses a configuration of three fixed load cells on a base mounting carriage. Each load cell is provided with a mounting block and overload stop, with the conveyor's load distributed equally among the three load cells. All three load cells are connected to a summing box, with a single load cell cable run from the scale back to the checkweigher controller. Dust and debris should be cleaned from this carriage on a regular basis, using low pressure air.

Thompson Scale's small package Checkweighers use a single-point load cell mounted directly beneath the weigh station conveyor or chain guides. It is protected by an overload stop beneath the live end of the load cell. Product accumulation around the load cell should be removed on a regular basis.

The weigh station should be checked and the scale verified once every 6 months. There are three tests that should be performed:

- Static scale stability test
- Dynamic scale stability test
- Scale corner shift test

6.1.2.1 Static Scale Stability Test

This test involves verification of the weigh station and scale with the weigh station conveyor off. The Checkweigher controller is to be placed into the Check Calibration screen (Main Menu item #2) and the display zeroed. A test weight is applied to the center of the weigh station. The displayed weight should immediately respond and display the test weight value. There should be no drift up to the weight or drift past the weight.

The displayed weight should remain stable, fluctuating no more than 2 increments in either direction.

Remove the test weight from the weigh station. The weight value should immediately drop to 0.00 and should not drift upward or downward.

6.1.2.2 Dynamic Scale Stability Test

This test requires successful completion of the static test first. Once this test is completed, place the Checkweigher in the Check Calibration screen (Main Menu item #2) and turn the weigh station conveyor on. There should be no more than 2 increments of oscillation in the displayed zero while the conveyor is running.

6.1.2.3 Scale Corner Shift Test

To perform this test, turn the conveyor off and place the Checkweigher controller into the Check Calibration menu (Main Menu item #2). This will provide a live reading of weight. Clear the scale from any product build up or residue before zeroing the scale.

1. With the weigh station conveyor off, place a known test weight at center of weigh station conveyor. Note weight reading
2. Now remove weight, make sure weight display returns to zero and place weight in same location again. Note weight reading.
3. Remove the weight and place at positions noted below, recording the weight in each position.

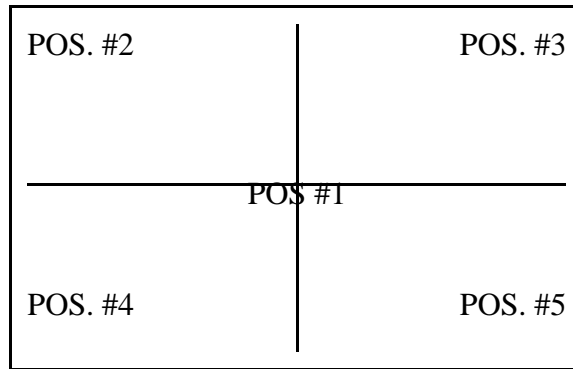

Scale Shift Test

All weight values should fall within +/- 2 increments of the reading recorded from position #1. If they do not, refer to Chapter 7 for detailed information on scale corner corrections.

6.2 Electrical Troubleshooting



WARNING: POWER MUST BE OFF BEFORE REMOVING OR INSERTING ANY CARD

The Checkweigher controller is comprised of five active printed circuit cards and a passive bus board, and LCD display module. Other optional cards may be installed as well, and are based upon purchased options for your system. Below is a diagram of the internal layout of the controller's back panel.

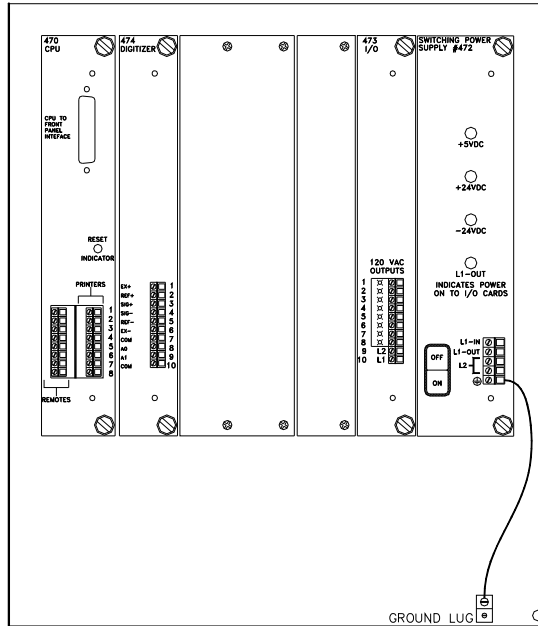

Checkweigher Back Panel

Verify that ALL indicator lights on the face of the #472 Power Supply card are ON when power is applied.

The Checkweigher controller back panel consists of an anodized aluminum card cage which surrounds the #471 Bus Board. Each card contained in the rack is supplied with a protective face plate with retentive mounting screws, terminals for interconnection to field devices, and legends identifying each card. Three (3) expansion slots are provided for the addition of other cards in the future.

Each card within the rack, and the interface board on the controller door is responsible for very specific functions, which makes troubleshooting very simple and straight forward. Each card within this rack and the interface board are described in detail below.

6.2.1 #470 CPU Card

The CPU card is placed farthest to the left in the card cage. The CPU has a single RED LED on the face plate that blinks like a heart beat to indicate the program is running properly. This card holds the Checkweigher program PROM, RAM memory and EEPROM memory. The 470 is also responsible for receiving all data from other I/O cards within the rack, and from the interface board on the controller door. As data is received, it is processed by the CPU and proper outputs are generated to the other devices within the system. The 470 is also responsible for generating and transmitting statistics data and remote display data.

The front panel of this card contains two parallel terminal blocks for connection of printers and displays as well as a DB-25 connector for connection to the #476 interface board. A status LED is also included, which blinks once every second to indicate that the CPU is running. Battery back up is also provided via a self-charging Ni-Cad battery pack and a self-charging memory back up capacitor. The Ni-Cad battery is responsible for maintaining the real-time clock module, while the memory capacitor holds data in RAM.

6.2.2 #471 Bus Board

The bus board lies within the card cage and includes edge connectors for each of the other cards in the rack. Filter components and a small regulated power supply is provided for communications purposes between each of the cards in the rack. This board is attached to the controller back panel via metal stand-offs, which provide a good ground grid for the card cage.

6.2.3 #472 Power Supply

At the far right end of the card cage lies the #472 power supply card. This card is provided with terminals for supply power, protected output voltage for connection to Input/Output card(s) within the rack, a power on/off switch, fuse and status LED's indicators for 110 VAC, 24 VDC and 5 VDC supplies operating on this card.

Components within this card provide a highly filtered secondary power supply to all components within the system, therefore it is not necessary to provide line filters or regulating transformers for the controller.

6.2.4 #473 Output Card

This card provides all the necessary relay outputs for remote zone light displays, reject devices and alarms for loss of calibration and trend alarms. The face plate provides terminals for switched and protected power (power comes from the #472 Power Supply card), and eight (8) relay output terminals.

This card can also be provided with eight 110 or 220 VAC input channels, and eight relay output channels for special systems. Each output channel has a corresponding LED to indicate actuation. Each output relay can accept 24 VDC to 220 VAC, depending upon power source connected to the #473's power terminals.

6.2.4.1 #573 Input/Output Card

As an option, your system may contain a 24 VDC I/O card in place of the #473 card described above. Reference drawings at the back of this manual for more information on the interconnection of this card.

6.2.5 #474 Scale Digitizer Card

The scale digitizer card is responsible for monitoring the weigh station load cell and filtering and then digitizing information received from the load cell. This information is then transmitted to the #470 CPU for processing. The face plate of this card contains a terminal strip capable of accepting + and - Excitation, + and - Signal, and + and - Sense leads from a wide variety of load cells or groups of load cells. This card can accept load cells with millivolt outputs from 1 to 3 mV.

6.2.6 #476 Interface Board

On the door of the controller, and directly below the LCD display module is the #476 interface card. This card provides connection of the LCD display, display back light inverter, and front panel keyboard. A flat ribbon cable connects the interface board directly to the #470 CPU, which interrogates and responds to information received from this card. The front panel keyboard connects to a 14 pin straight connector at the bottom of this card, and the keyboard connects via a 25 pin connector at the top.

On environmentally protected systems, this card may also contain special terminals for connection of an intrinsic safety barrier to protect the keyboard.

6.2.7 #477 Traffic Control Card

This optional card provides a full duplex serial port configured as RS-232, or RS-422, and can be used for remote data up/down loading, or for special features available with this Checkweigher system. This card, if included in your system, will reside in place of an existing expansion slot within the rack.

6.3 Troubleshooting Guide



WARNING: POWER MUST BE OFF BEFORE REMOVING OR INSERTING ANY CARD

6.3.1 Controller display shows meaningless data or no data

Display is driven through commands created by the #470 CPU. It is interconnected via a 25 conductor ribbon cable from the CPU to the #476 interface board, and another short 25 conductor cable from the top of the #476 board to the bottom edge of the display.

Check all connections to make sure they are properly seated.

Failure of the #470 CPU. Replace and power controller up.

Failure of the #476 interface board

Blown fuse or defective power supply board.

It is also possible to have induced interference from outside static or EMI/RFI sources. These sources generate a large enough magnetic or radio field that it can disrupt the information displayed on the LCD. Cycling power to the controller typically clears this problem, but the source of the “noise” should be located and squelched. Placing snubbers across motor starter or relay coils in or in the immediate area of the controller usually help with this problem, and finding and grounding to address static problems also helps greatly.

6.3.1.1 Display is black or characters not visible

It is possible that either the lamp for the display back light has failed or is out of adjustment. Locate the contrast adjustment potentiometer on the #476 board, found directly below the display. This potentiometer is light blue in color with a white center screw. Adjust to achieve the desired contrast on the display.

If the back light has failed, the display will require replacement.

6.3.2 Front panel keyboard not working properly

Check connector for keyboard on #476 interface board. Two (2) red LED's are located in the bottom left corner of the #476 board. One blinks on and off once every second, and is an indication that the processor on the #476 is functioning properly. The 2nd LED blinks whenever a key on the front panel keyboard is pressed. This can be used to provide visual confirmation that specific keys are being read by the #476 board

Defective keyboard overlay (see note above)

Defective #476 interface board

Defective #470 CPU board

6.3.3 Improper rejector operation

The Checkweigher controller contains two timers for operation of the reject device. Check these timers for proper settings. If Time Duration is set to zero or higher than 25 seconds, reject output will not actuate.

Defective #473 Output card. Place test meter on VAC and place leads across output #8 and Neutral. Actuate reject by pressing down on weigh station as bag crosses conveyor. Output signal should actuate and produce 110 VAC for the times set as noted above, and corresponding LED on output card should light.

#473R output card uses relay outputs. Although the standard controller is configured for 110 VAC outputs, your's may have been modified to produce other voltages. Please check and verify before performing the test described above.

Failure of reject mechanism or reject solenoid valve. If 110 VAC signal is properly generated by the reject output, then the problem lies with the field equipment or wiring.

6.3.4 Remote Zone Light Display not operating properly

As with the reject signal, all outputs for the zone display are generated by the #473 Output card. Follow directions above for checking output voltages.

Failure of lamp in light display.

6.3.5 Erratic or incorrect weighments

Interference from up or down stream conveyor with weigh station conveyor

Interference by restrictive or improperly installed photo-eyes or other sensor placed on weigh station conveyor

Mechanical bind or interference with weigh station scale base.

Mechanical problem with weigh station conveyor belt, drive components, or pulleys.

Load cell not properly grounded. The shield from the load cell cable must be attached to the Ground terminal on the #474 card. If there is a splice in the load cell cable, check to see if the shield ground was continued in the new cable and not tied to ground at the splice.

Scale base rocking on high corner. If the scale base was installed on a floor, check to see that the scale was properly mounted and secured to the floor.

Scale base frame distorted from improper installation. If the scale was mounted to an uneven surface, shims should be placed below the low corner to stabilize the scale. Do Not tighten mounting hardware to a point that distorts the scale frame.

Packages crossing the weigh station are too close together. One package must be exiting the weigh station conveyor before another may begin onto the conveyor. That is the weight of the first unit must terminate before the second package begins onto the scale.

Conveyor motor connections not flexible enough. There must be at least one 90 degree bend in the SO cord or flexible conduit between the motor and the J-box or conduit LB. This is required to provide a "spring" or repeatable and movable load for which the scale and controller can compensate.

Excessive vibration caused by poorly constructed or improperly installed weigh station scale and conveyor. Low frequency vibrations caused by fork-lift traffic can affect the scale if it is not properly installed. See Chapter 7 for more information on proper installation.

The Run Checkweigher screen displays an indicator for an update to the Checkweigher's auto zero routine. This routine runs between package weights and should occur on a regular basis. An indicator of "AZ" will appear in the far upper right corner of the screen. If this indicator does not appear, either there is too much vibration induced into the scale or packages are too close together and not allowing enough time for the auto zero to be updated.

Side load from wind generated by a fan or open outside door. Although the breeze feels good to you and me, it is essentially the force of the wind that cools us off. This force is also exerted onto the weigh station scale causing fluctuations in weights. Remove the source of the wind, or place wind guards around the weigh station conveyor and scale.

Failure or defective #474 Scale Digitizer card. Using digital volt meter, place meter on VDC and place leads across +EX and -EX terminals. Voltage should be a nominal 10 VDC. Place leads across +Sig and -Sig. Reading should be between 17 and 45 mV.

6.3.6 Failure of controller to zero scale

The Checkweigher's #474 load cell digitizer card contains digital potentiometers and successive approximation components. These devices automatically zero a scale system during calibration. If the load cell is damaged by either force or shock overload, the digitizer circuitry will not be able to fully adjust and compensate for the large difference in the resistive readings of the load cell. A warning message may appear during calibration that states it is unable to complete calibration.

After reaching the step in calibration that asks the operator to remove any weight and turn off the weigh station conveyor motor, it asks the operator to press Enter to continue. At this point, the controller reads the load cell and generates a digital offset to match the dead load on the scale. If the top number shown on the screen during this step does not move, the load cell has been damaged and should be replaced.

The Run Checkweigher screen displays an indicator for an update to the Checkweigher's auto zero routine. This routine runs between package weights and should occur on a regular basis. An indicator of "AZ" will appear in the far upper right corner of the screen. If this indicator does not appear, either there is too much vibration induced into the scale or packages are too close together and not allowing enough time for the auto zero to be updated.

6.3.7 Statistical Package does not print reports

Wiring at controller, or printer interface enclosure not properly connected. See Interconnection diagram at the back of this manual.

Printer connector not plugged in to printer.

P.C. board in interface enclosure not plugged in or defective.

6.3.8 One Last Hint

After following the above suggestions for troubleshooting your particular problem without conclusive results, remove all cards from the rack and replace. If the problem is solved, cards can be replaced one-by-one until the source of the problem is discovered.

It is always recommended that a set of spare printed circuit cards be kept in stock to assist you in troubleshooting this equipment. Although the Checkweigher is built to the highest standards, and of the highest quality components available, problems may occur due to unforeseen circumstances.

Chapter 7

Weigh Station Conveyor & Scale

The Model 4693 Heavy-Duty Checkweigher is comprised of three components; Weigh Station Conveyor, Weigh Station Scale Base, and the Checkweigher controller. Systems may also include optional support structures, in-feed pacing conveyors and/or reject conveyors.

This chapter is dedicated to the proper use and maintenance of both the Weigh Station Conveyor and Scale base, and includes important information that should be reviewed by both operators and maintenance personnel to insure reliable and accurate operation of the Checkweigher system.

7.1 Weigh Station Conveyor

Thompson Scale Co. engineers design each weigh station conveyor to meet the specific needs of the application. Although our “standard” weigh station conveyor is 48" in length, with a 24" wide belt, other lengths and widths are commonly used. The length of the conveyor is typically based upon the maximum product length, conveyor speed, and production rate. Belt width is usually determined by either the product’s maximum width, or width of surrounding conveyors.

All conveyor use common parts and sub-assemblies. These parts include bearings, drive motors and gear boxes, pulleys and idler rollers. Although your particular conveyor may vary in length or width, all information contained in this chapter will apply to your system.

7.1.1 Proper Conveyor Installation

Chapter 2 of this manual covers installation of the weigh station conveyor and scale base. Please refer to this chapter for detailed information on proper installation of these components. A weigh station assembly drawing and conveyor layout drawing are also provided at the back of this manual.

7.1.1.1 Conveyor Speed Considerations

For the Checkweigher to weigh packages properly, the in-feed conveyor ahead of the checkweigher must be running at the same speed as the checkweigher. It is also important that the out-feed conveyor, down stream of the checkweigher, run at the same speed as well.

As a package enters the weigh station conveyor, weight data is constantly collected and stored for analysis. If the in-feed conveyor is running slower than the checkweigher conveyor, the checkweigher conveyor will exert force trying to “pull” the slower moving package onto the weigh station conveyor. This force is interpreted as weight. This also holds true if the in-feed conveyor is running faster than the checkweigher conveyor. In this case, the package is being “pushed” onto the weigh station conveyor, which in turn exerts force on the scale. These principals also hold true for packages leaving the weigh station conveyor.

7.1.1.2 Weigh Station Conveyor and Scale Stability

To allow for the highest possible accuracy and repeatability, it is essential that the weigh station conveyor and scale base are extremely stable. Once the weigh station has been mounted in place, check to insure that the scale base, scale base lid, and conveyor do not rock, tip, or appear unstable. If any form of instability is detected, take the time to remove components one by one until you find the problem.

Any support structure used with the weigh station should also be checked for stability. If the stand moves, twists, wobbles, or appears unstable in any way, provide additional cross and knee bracing wherever possible to achieve complete stability. Stability of the stand can be easily checked by running the weigh station and surrounding conveyors, running product across the conveyors, and by stopping the conveyors. If the stand or weigh station conveyor appear to be moving, rocking, tipping, twisting, or shaking during any of these events, it will be necessary to correct the problem before using the checkweigher.

7.1.2 Weigh Station Conveyor Adjustments & Maintenance

Each weigh station conveyor has been fully tested and run for a minimum of 6 hours before shipment to insure proper belt alignment and tension, and bearing and motor operation.

The weigh station conveyor is comprised of 4" dia. flat-faced, V-grooved dynamically balanced head and tail pulleys, a high precision 2-1/2" dia. Idler roll with sealed-for-life bearings, and a 2 ply "Check-out" style, B-Section (with V-guide) conveyor belt. Motor, gear box, bearings, and other components are listed in detail on the Bill of Material found on the conveyor layout drawing at the back of this manual.

7.1.2.1 Conveyor Belt Tension Adjustment



CAUTION: DO NOT OVER TIGHTEN CONVEYOR BELT. THIS WILL DAMAGE THE BELT, BEARINGS, AND HEAD/TAIL PULLEYS!

The flat-faced V-grooved head and tail pulleys, and the V-guide on the underside of the conveyor belt provide positive tracking for the conveyor belt. Belt tension should be adequate to repeatably move a full package off the weigh station conveyor from a full stop condition. Typically on a 48" long weigh station conveyor, the belt can be lifted approximately 3" at the mid-point between the head and tail pulleys.

7.1.2.2 Conveyor Pulley Alignment

To align the driven pulley, take a measurement from a fixed location on the bearing's take-up frame to the center of the pulley shaft. Move to the other side of the same pulley, and make the same measurement from the same location on the other take-up frame, adjusting until measurements from both sides are equal.

7.1.2.3 Lubrication Schedule

Head and Tail pulley bearings should be lubricated with a lithium based grease conforming to a NLGI Grade Two specification. Bearings should be lubricated every 2 to 3 months, dependent upon the operating environment. Environments containing abrasive or corrosive contaminants require more frequent bearing lubrication.

Gear Reducers are pre-filled at the factory and sealed for life. Gear reducers do not contain breather vents, so should not experience loss of fluids.

7.1.2.4 Head and Tail Pulley Maintenance

The head (drive) and tail (driven) pulleys on the Checkweigher weigh station conveyor are specialized pulleys, and require proper use and maintenance. It is imperative that pulley bearings are properly maintained and replaced if showing signs of wear. If a bearing squeaks, lubricate first, and replace if noise is not eliminated.

Since these pulleys are precision balanced to provide vibration-free operation of the weigh station conveyor, over tensioning the conveyor belt, impacting the pulley faces, or allowing a bearing to score the pulley shaft will require replacement of the damaged pulley. If an out-of-round pulley is allowed to remain on the weigh station conveyor then weight accuracy and repeatability will be severely affected.

Pulley faces should be checked every 12 months for excessive wear or product build-up. Build-up should be removed, and pulleys replaced if wear has caused damage to the pulley.

7.2 Weigh Station Scale Base

The scale base included with your Heavy-Duty Checkweigher system is a model FS-2424 flexure scale manufactured by Thompson Scale Co. The FS-2424 measures 24" x 24" square, and has a full load capacity of 250, 300, 500 or 1000 Lbs. The FS series scale base is constructed of epoxy coated mild steel with stainless steel flexures and lid, with a load ratio of 1:1. The load cells used in these scale bases are nickel plated tension/compression S-type load cells rated at 3mV/V, and are available through your local scale dealer or Thompson Scale Co.

Special application checkweighers may require larger scale bases. Specific engineering drawings and data will be provided with these systems.

Although this scale base is both rugged and accurate, damage can occur if improperly handled.

The bottom of the scale base is pre-drilled on 22" centers with ½"-13 tapped holes. Prior to shipment, two overload protection straps are installed to protect the load cell and flexures during shipment. The scale is then loaded into the nesting frame of the conveyor for transportation to you or your vendor.

The following diagram shows location of the scale base's major components and the location of the shipping straps which must be removed after installation and before operation.

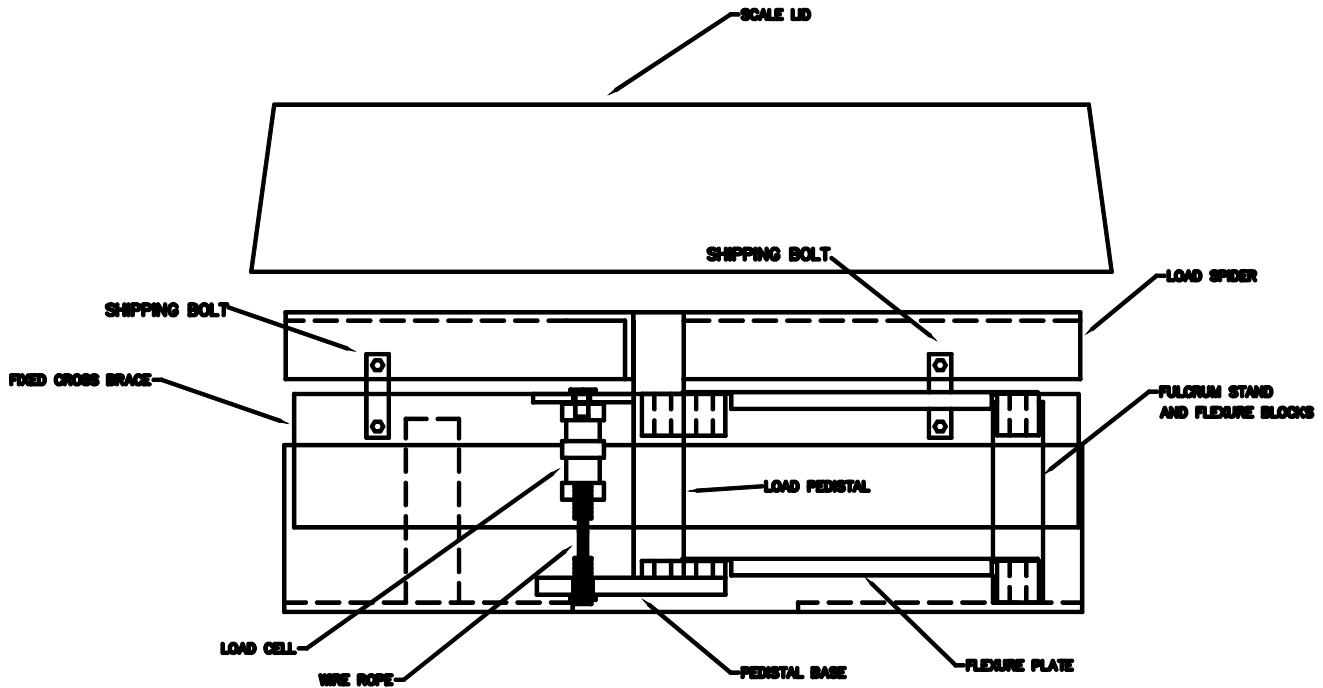

The scale base must be mounted to a rigid and stable platform, or to a level floor. In either case, jack bolts may be installed to provide a means of leveling the scale. These bolts should be threaded through the 1/2"-13 holes in each corner of the scale, and held in place with a jam nut from either the top or bottom. To adjust, loosen the jamb nut and slowly raise or lower the scale corner until level is achieved.

It is extremely important to keep the scale in proper alignment and not allow any single corner to twist the scale base frame. This will cause inaccurate and unreliable scale readings, and can cause permanent damage to the scale.

7.2.1 Changing the Load Cell

If damage has occurred to the load cell, and the load cell must be replaced, follow the steps listed below. Refer to the troubleshooting guide in this manual for information on testing the load cell.

1. Back off retaining bolts from weigh station conveyor nesting frame. Remove the weigh station conveyor and secure while working on the scale base.
2. Remove the top lid from the scale. Remove the load cell cable through the access hole in the side frame of the scale base.
3. The load cell is suspended from the main flexure lever via a wire rope. This wire rope has threaded studs at either end, one passing into the load cell, and the other into the main load post. See figure below.

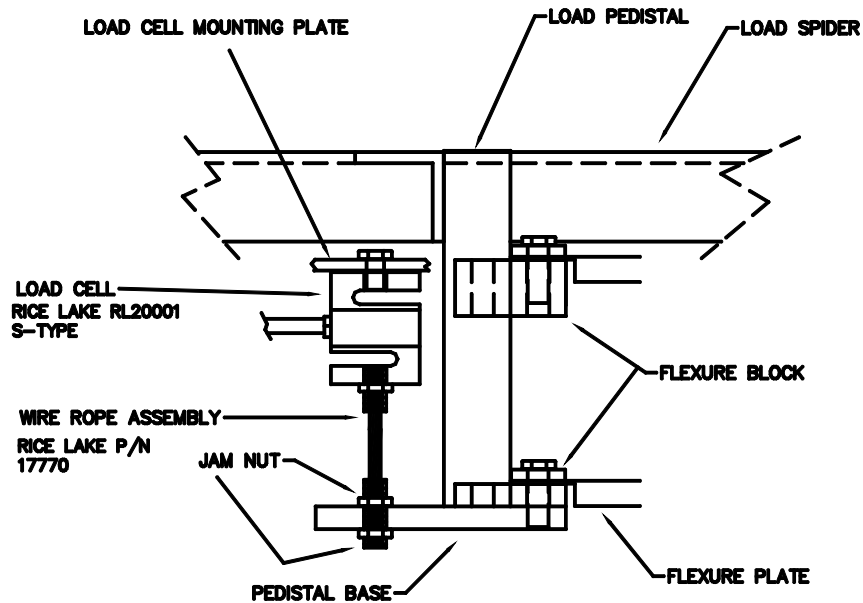

4. First, remove the wire rope retaining nut from the underside of the load post. See figure below. Now loosen the hex bolt at the top of the load cell housing. The bolt should be backed out by hand.
5. Once the bolt has been removed from the load cell housing, gently remove the load cell from the housing and gently pull the wire rope from the load post.



CAUTION SHOULD BE TAKEN WHEN REMOVING THE LOAD CELL. IT IS IMPORTANT NOT TO TURN THE WIRE ROPE STUD INTO OR OUT OF THE LOAD CELL OR TO MOVE THE TOP RETAINING NUT FROM THE WIRE ROPE STUD FROM THE FLEXURE LEVER.

6. Noting the location of the wire rope in the load cell, remove the wire rope and place in the new load cell. Hint: This can be done by counting the number of turns it takes to remove the wire rope from the old load cell.
7. Gently place the wire rope stud back through the hole in the load post. Align the load cell with the top mounting hole, and thread the bolt into the top of the load cell but do not tighten.
8. Replace the retaining nut on the underside of the flexure lever. Tighten to hand tight plus 1/4 turn. Tighten the bolt on top of the load cell housing.

If all has gone properly, the scale base should not need any further adjustment. Before the weigh station is reassembled, the scale should be checked for corner accuracy. Refer to the Troubleshooting guide for corner check procedure.

7.2.2 Weigh Station Scale Corner Corrections

The scale base corner to corner readings should be within +/- 2 graduations. If the corner readings of the scale base are not within this tolerance, a corner correction must be made. Each flexure plate within the scale ties the top load spider to the fixed cross bracing within the scale. Each end of each flexure plate is bolted to a fixed block. In a perfect scale, top and bottom fixed blocks would be exactly the same distance apart. Since there is no such scale, shims are used to adjust the distance top to bottom between flexure plates.

It should only be necessary to adjust the “A” and “D” top fixed blocks and flexures. These are identified in the diagram below.

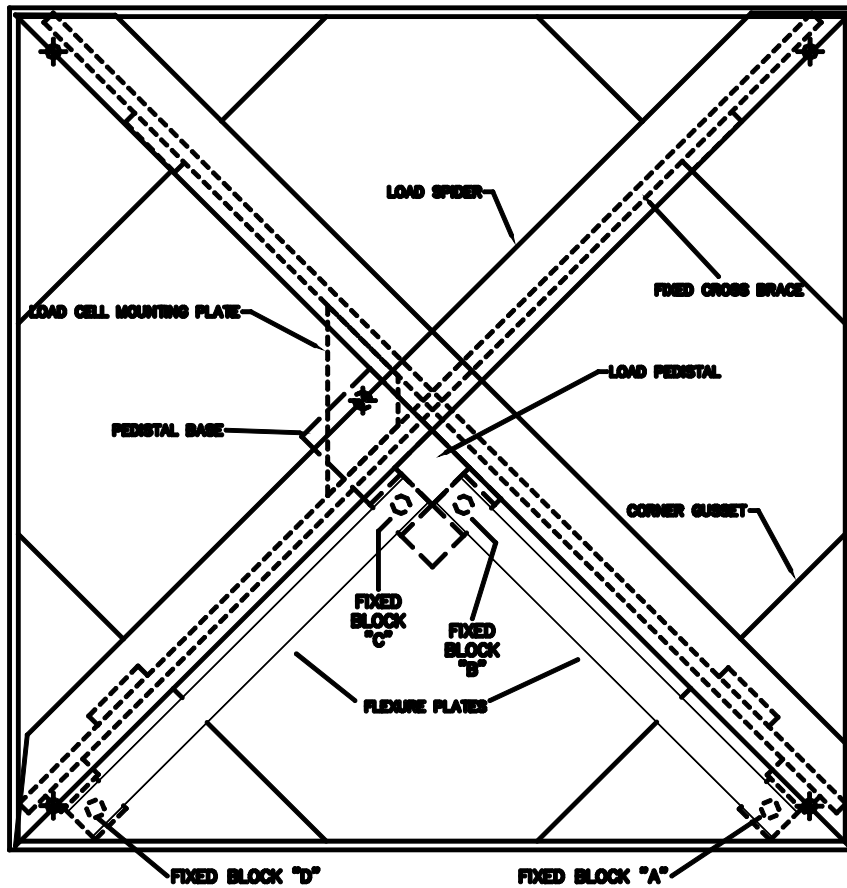

Opposing corners of the scale are affected by one another. If the corner above fixed block “A” reads 49.90 lb., and the opposing corner (upper left corner in the drawing) is 50.10, then adding a shim to fixed block “A” will increase the corner reading above “A”, and decrease the opposing corner’s reading.

To make a change of 0.10 pound, add a 0.005 shim.

If corner readings are more than 1 pound out of tolerance, please contact the factory for information on repair or replacement of this scale base. See the Shim Placement diagram on the following page:

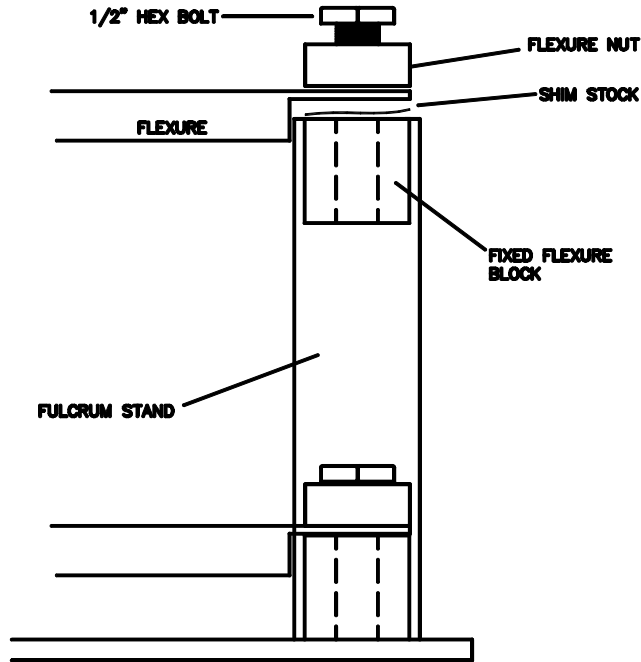

7.2.3 Scale Base Lid Adjustment

Although it is a rare occurrence, the scale base lid can become warped due to stress in shipment or improper installation or over-tightening of the weigh station conveyor retaining bolts.

If the conveyor appears to rock high on one corner, which can be noticed as product transfers across the conveyor, then the conveyor should be removed and the scale inspected. If the rocking motion comes from the scale lid, remove the lid and tape a small flat washer onto the end of the load spider that appears to be low. This washer may be held in place with a small piece of tape until the lid can be replaced.

If the rocking motion appears to come from the entire scale, check the mounting hardware holding the scale in place.

Chapter 8

Checkweigher Features & Purchase Options

This chapter is dedicated to software features included with the Checkweigher and optional software and hardware accessories that can be purchased for use with the Checkweigher. All options and accessories can be added either at the time the Checkweigher is purchased or at any time after installation. Addition of any of these options does not require a factory technician to install, and rarely requires modification to the existing components within the Checkweigher controller.

8.1 Features Included with Checkweigher

The Checkweigher controller includes programming and feature sets that allow for viewing real-time production statistics, alarming, rejecting and output of production weights and data via a serial connection.

8.1.1 Checkweigher Run Screen Statistics

The Checkweigher Run screen is where the display resides during production. This screen provides display of the last unit weight, product recipe information and status on the auto zero routine running in the program's background. In addition, information on production totals are offered, showing total units, total weight, a break-down of units categorized in five weight zones and a Mean Unit Weight.

Refer to Chapter 4 "Controller Setup" for details on each of these features.

8.1.2 Weight Zone Outputs

As part of the production statistics displayed in the Checkweigher Run screen, five boxes display category into which the last weight has fallen. The zones are adjustable by setting the Target weight, Low Reject, Low Pass, High Reject and High Pass values within the product recipe. Weights are compared to these parameters and then placed into the corresponding zone. The Checkweigher displays the appropriate zone on the front panel display and also actuates an associated zone output on the #473 (110 VAC) or #573 (24 VDC) Output card.

The zone output is turned on and remains on until the next package is weighed. The current zone output is turned off a few milliseconds before the new zone output is energized. If the new weight falls into the same zone as the last, no change in zone output can be detected with the naked eye.

The optional Model RZDP3 (3 light tower) and RZDP5 (5 light tower) are offered as accessories by Thompson Scale. These light towers offer a 360 view, and are stacked one atop another. Low Reject is a RED light mounted to the bottom of the tower, followed by Low Pass, which is YELLOW, followed by the Good zone, which is GREEN. High Pass is on top of Good, and is YELLOW, and finally High Reject is on top of the stack, and is RED. If configured as a 3-zone tower, the yellow lights are removed.

The RZDP light tower (either 3 or 5 zone) is mounted to a base unit, which contains wiring terminals and a method to mount the tower to either an enclosure or the end of a piece of ½" rigid conduit. Thompson Scale provides the light tower mounted to either the Checkweigher controller cabinet or to a NEMA 4 painted metal enclosure.

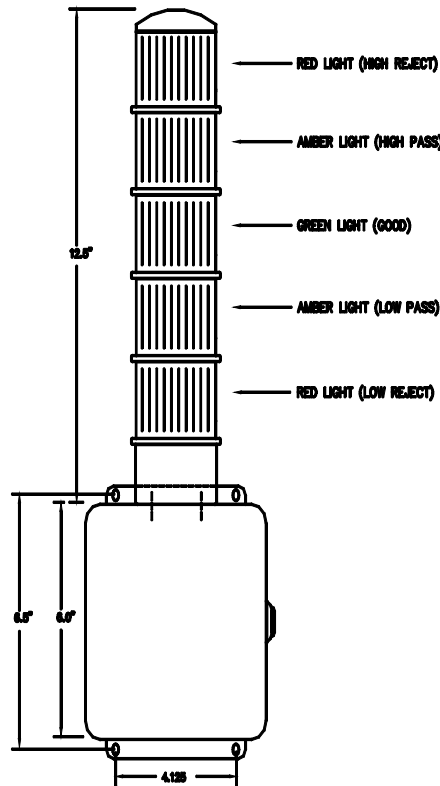

RZDP5 Remote Zone Tower

Zone outputs can be connected to other devices, such as counters or PLC inputs.

8.1.3 Reject Outputs

As a package is weighed and classified, it may be deemed as being out of tolerance and require removal from the production line. The Checkweigher controller contains a timed reject output that by default is configured to actuate a dedicated output for either low or high weight rejected packages.

It is possible to configure the Checkweigher controller to actuate one timed output for low-weight packages and actuate a separate timed output for over-weight packages. The Checkweigher’s configuration menu contains variables that can be adjusted to provide the desired reject actuation.

As a purchase option, the Checkweigher controller can be configured to accept the reject signal of an upstream device, such as a metal detector. In turn, the Checkweigher controller will provide timing functions for tracking the offending package across the scale and to the reject device of choice.

See **Chapter 5 “Configuration”, Section 5.2.7** for details on configuring these outputs.

8.1.4 Remote Serial Port

The #470 CPU card (far left in card rack) contains a serial output port configured as a 20mA current loop. See **Appendix A** for more information on protocol and how this port functions.

The remote port can be configured to operate in several ways, with the default being “Stream” Mode. This mode transmits out the last package weight continuously until another package weight is generated. This default is normally used for connection of remote digital displays that echo the last package weight at a location other than the Checkweigher controller.

See **Chapter 5 “Configuration, Section 5.2.2** for details on configuration and use of this serial port.

8.1.4.1 Universal Remote Digital Display

Thompson Scale offers two styles of remote digital displays capable of providing the operator with weight data at a location remote from the Checkweigher system. These displays include:

RL16 - a 1" high, 6 digit LED display housed in a NEMA 4X fiberglass enclosure

RL26 - a 2" high, 6 digit LED display housed in a NEMA 4X fiberglass enclosure

Regardless of the type of display used, weight data is continuously displayed, and updated as each unit is weighed on the Checkweigher system. Refer to the specific remote display manual for information on installation, configuration and troubleshooting.

8.1.5 Trend Alarm & Reject Overweight Alarm

Checkweighers supplied without the optional STPR production reporting package show Main Menu item #6 as “Trend Alarm”. Checkweighers with the STPR package show Main Menu item #6 as “Statistical Data”. Within this menu is a submenu containing settings for the Trend Alarm feature.

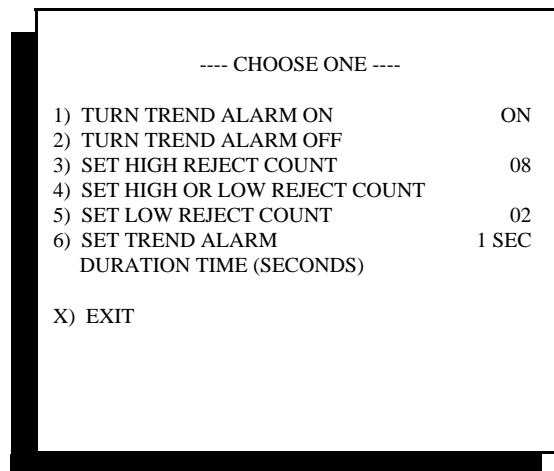

Trend Alarm Settings

The Trend Alarm allows the user to select a consecutive number of either under-weight rejects, over-weight rejects or under and over-weight rejects that can occur before triggering an alarm output. Once values are set, they are used for comparison of rejects from any product recipe and production run. The Trend Alarm, Output #7 on the #473 or #573 I/O card, will be actuated for the duration of time set in this menu.

8.1.5.1 Reject Overweight Alarm

A setting within the Checkweigher's configuration menu (**See Chapter 5, Section 5.2.9.8**) allows the user to change the function of the Trend Alarm. The Reject Overweight Alarm function will actuate Output #7 on the #473 or #573 I/O card when the accumulated weight of rejected packages reaches a specified value.

Selecting this function from the configuration menu will disable the Trend Alarm feature.

8.1.6 Digital Security Lock

Each Checkweigher controller contains a set of digital inputs for connection to a key-operated switch, providing security against unauthorized changes to product weight data or calibration. The #476 Keyboard Interface Board, located on the inside of the controller's door, contains a 10 position terminal block in the upper right corner of the board. These digital inputs can be connected to a switch, providing three types of hardware security lock:

1. Restrict Access to Product Weight Data
2. Restrict Access to Calibration
3. Restrict Access to both Product Weight Data & Calibration
4. Limit Operator Access to "Run Checkweigher" Screen ONLY

The Checkweigher controller is shipped with jumpers installed on this terminal block to allow access to all portions of the controller's program. Refer to the interconnection drawing at the back of this manual for information on connection to these inputs.

Any type of selector switch may be connected to these terminals, as specified on this drawing. Thompson Scale offers several styles of switches, and will gladly assist in selection of a switch suited for your specific purpose.

8.2 Hardware & Firmware Purchase Options

Both hardware and firmware options can be purchased for use with the Checkweigher, and can be added at any time before or after installation. Each option is detailed below:

8.2.1 Closed-Loop Feedback

The Checkweigher controller can be supplied with a closed-loop feedback circuit designed to monitor package weights, takes an average of a set number of packages, and then output a response back to the packaging or slicing machinery to adjust for more accurately package weights. There are three types of feedback:

1. Counter Feedback
2. Serial Feedback
3. Servo (pulse) Feedback

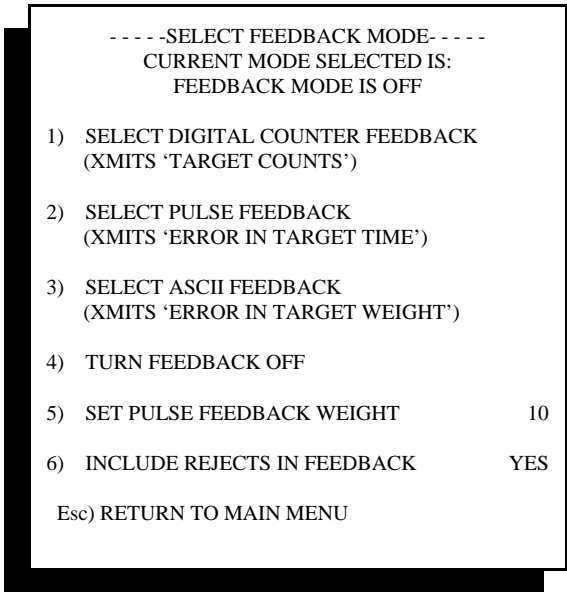

Feedback Functions

Additional settings, shown in the menu above, are described in the Configuration menu, Chapter 5, Section 5.2.14 Please review these settings and select those appropriate for your application.

All three types offer the same method of gathering weight data. Two variables are used; Sample Count and Sample Frequency. Each is described below:

Sample Count is set to the number of unit weights to average for determining the deviation from Target Weight. If this value is set to 10, then ten packages will be weighed. Package weights are summed and then divided by ten. This value is then compared to the Target Wt. Let's say that the average of 10 units equaled 10.09 lb. If the Target Wt. was 10.00, the deviation from Target would be +0.09.

Sample Frequency is set to the number of packages between the packaging machinery or slicer up-stream and the Checkweigher. In performing closed-loop feedback you want to collect a sample, make a change, and then collect another sample to see where you are. Since there may be 5, 10, or 20 packages between the up-stream machinery and the Checkweigher, you do not want to induce a change and then immediately take another sample. You need to wait until the first package with the induced correction crosses the Checkweigher before beginning to collect more data.

Each type of closed-loop feedback offers menu settings within the product recipe, and will be defined below.

8.2.1.1 Counter Feedback Loop

This option gives the operator a setting for the number of counts per weight, for example; 1000= 1.00 lb. Using this reference, the Checkweigher controller automatically calculates the number of counts to add or subtract to the current count. This option also allows the operator to enter the total counts for the Target Wt. The Checkweigher controller then displays the entered value with the Target Wt. and the current or adjusted count.

The entered value is never changed, but the adjusted value can be referenced by the operator to allow for a manual update to the entered value. Count values are transmitted and can be received for verification via RS-232 or RS-422.

To set these variables, go to the product recipe screen by starting at the Main Menu, selecting “5) Select/Edit Recipe”, and then either entering a new recipe or selecting an existing recipe to edit. Enter into “3) Change Product Weights”, and the following screen will be displayed:

1) HIGH REJECT	51.00 LB
2) HIGH PASS	50.50 LB
3) TARGET WEIGHT	50.00 LB
4) LOW PASS	49.90 LB
5) LOW REJECT	49.50 LB
6) CONTAINER WEIGHT	0.60 LB
8) SET FEEDBACK FILL PARAMETERS	
ESC) RETURN	U) WEIGHT UNITS

Recipe with Feedback

Select item #8 “Set Feedback Fill Parameters”, and the screen shown below will appear:

FEEDBACK FILL PARAMETER ADJUSTMENT	

1) ADJUST FEEDBACK SAMPLE COUNT	
2) ADJUST FEEDBACK SAMPLE FREQUENCY	
3) ADJUST FEEDBACK SAMPLE CORRECTION	
4) ADJUST FEEDBACK TARGET COUNTS	
5) ADJUST PERCENT OF HIGH SPEED FILL	
X) EXIT	

Count Feedback Settings

Sample count and sample frequency are described on the previous page.

Sample correction offers a choice of the amount of correction to induce. Choices of 25%, 50%, 75% and 100% are offered. As an example, if 50% were selected, and the actual error derived from the last set of samples was 1 lb., the controller would induce an error of ½ lb.

Target counts is equal to the number of counts required to reach the target weight. This value is entered empirically, and is adjusted as fills and weight checks are done. For example, if the value were set to 1,000 counts, but it actually took 1,200 counts to reach your Target weight as entered in the checkweigher, the feed-back loop would adjust this number upward until the 1,200 count value was reached. This value is stored when it is updated.

When the user changes from this recipe to another, the most current count is stored in memory and becomes available when this recipe is loaded again in the future.

Percent of High Speed Fill is an additional feature that can be used to communicate with the filler and provide a set of separate counts for a high-speed (bulk) fill and a low-speed (dribble) fill. If, for example, a total count of 1,000 was required to fill the package to Target weight, and Bulk fill was 70% of the fill, then this value would be set to 70. When the checkweigher transmitted updated information to the filler, it would sent 700 for Bulk and 300 for Dribble.

8.2.1.2 Pulse Feedback

Pulse feedback sends one of two fixed timed 110 VAC outputs; one for plus (+) adjustment, and one for minus (-) adjustment. The length of the pulse is determined by both the decimal point set in the 4693 controller, and by the Pulse Feedback Weight value selected in the configuration menu for feedback. See 8.2.1, above.

If, for example, the checkweigher controller is set to no decimal and the Pulse Feedback Weight value is set to 1, then each pulse output by the controller is equal to one (1) increment. [target weight of 50g, each pulse would be equal to 1 gram]

If, for example, the checkweigher controller is set to one decimal, and the Pulse Feedback Weight value is set to 1, then each pulse output by the controller is equal to one-tenth increment (0.1). [target weight of 50.1g, each pulse would be equal to 0.1 gram]

When Pulse feedback is selected, a new menu selection is presented within each product recipe menu, as shown below:

1) HIGH REJECT	51.00 LB
2) HIGH PASS	50.50 LB
3) TARGET WEIGHT	50.00 LB
4) LOW PASS	49.90 LB
5) LOW REJECT	49.50 LB
6) CONTAINER WEIGHT	0.60 LB
8) SET FEEDBACK FILL PARAMETERS	
ESC) RETURN	U) WEIGHT UNITS

Recipe with Feedback

Selecting item #8 “Set Feedback Fill Parameters willl present the following screen:

FEEDBACK FILL PARAMETER ADJUSTMENT	

1) ADJUST FEEDBACK SAMPLE COUNT	
2) ADJUST FEEDBACK SAMPLE FREQUENCY	
3) ADJUST MAXIMUM NUMBER OF PULSES	
X) EXIT	

Pulse Feedback Settings

Sample Count and Frequency are described above, in Section 8.2.1

Adjust maximum number of pulses allows the user to set the absolute maximum adjustment that can be made by the checkweigher controller. This feature allows the user to limit the amount of adjustment that can be made in a single correction.

Outputs for the pulse feedback are located on the #477 card, provided as part of the feedback option, with outputs detailed on electrical drawings found at the back of this manual.

8.2.1.3 ASCII Feedback

ASCII feedback transmits out a actual error from target weight back to the up-stream filling machine. Multiple units (sample count) pass across the checkweigher, their weights averaged, and the resulting error from target is determined and transmitted as:

STX (start of text)

+ or - symbol for polarity of error

data actual error value. Value is set by checkweigher's decimal and increment (divisions)

CR (carriage return)

LF (line feed)

ETX (end of text)

Protocol of this port is fixed at 9,600 Baud, 1 start bit, 8 data bits, 1 stop bit, no parity

8.2.1.4 Turn Feedback Off

This function allows the user to disable all closed-loop feedback features. This is useful when troubleshooting a problem with the checkweigher or filling equipment. Select this feature, and the status line at the top of the display will change to "OFF"

8.2.1.5 Set Pulse Feedback Weight

See description in 8.2.1.2, above

8.2.1.6 Include Rejects in Feedback

This variable allows the user to qualify the weight data gathered by the checkweigher, and can either provide weight correction and feedback based upon all weights crossing the checkweigher, or by a select group of weights crossing the checkweigher.

If set to "No", all weight values that fall outside of either low or high reject limit will be omitted from feedback calculations. In addition, all weight values that fall between low and high pass and good will be omitted. This leaves only weight values that fall between low and high pass and low and high reject:

Low Reject

-----Included

Low Pass

Good

High Pass

-----Included

High Reject

This configuration makes no change to production weights, if they fall into the reject category, and makes not change if they fall within the "good" region.

8.2.2 Remote Product Load

It is possible to connect between the Checkweigher controller and a remote device, such as a PLC, Industrial computer/software or a PC and have the remote device create and then call unique product recipes from the Checkweigher.

This feature can be used in an application where there may be multiple pieces of equipment on a production line; filler, Checkweigher, palletizer, etc. that require change-over when changing from one product type or weight to another. For example, programming within the palletizer controls can generate a set of commands to the Checkweigher, changing it from the current product recipe to a new recipe. In addition, it is possible to send commands to create new recipes, call for production reports and clear data from the Checkweigher's memory.

Complete set of commands and use of this feature are contained in an Appendix not provided with our standard manuals. Contact Thompson Scale Co. to receive an electronic copy of this Appendix.

8.2.3 Ethernet (TCP/IP) Port

The Checkweigher can be provided with an Ethernet port for connection to a system network. The port is fully configurable and addressable via a simple program loaded into either a laptop or desktop computer.

The #484 card is installed into the Checkweigher's card rack. The output for the Ethernet port is a RJ-45 plug.

The Remote Product Load option, described above in Section 8.2.2, and in Appendix C, can be used in conjunction with the Ethernet port.

Other topologies and protocols are available upon request. Please contact the factory for assistance.

8.2.3.1 Ethernet IP Port

Thompson Scale Co. also offers a serial to Ethernet IP protocol converter for direct communications with Allen-Bradley® PLC's. See Appendix E "Ethernet IP" in this manual.

8.2.4 Analog Output Port

A serial to Analog output converter can be purchased and installed into the Checkweigher controller. This option requires a #477-232 RS-232 serial card for the controller's card rack and the serial to analog converter. The output of the converter is either 0-10 VDC or 4-20mA. Data is output with a 16-bit resolution and is adjustable for baseline and output. As each unit weight is generated by the Checkweigher, the converter generates a spike in voltage/current output equal to the weight value, and then returns to the baseline output.

Complete user's manuals and installation and operations instructions are provided with this option.

8.2.5 Reject Devices

Thompson Scale Co. offers a wide variety of methods for removing off-spec packages or products from the conveyor line. These include side-push rejection, diverters, classifiers, drop-nose conveyors and for light products, an air blow-off reject.

All reject devices are either incorporated into or are adjacent to the Checkweigher, and by default are wired directly to the Checkweigher for operation. Depending upon the application and style of reject, we often recommend the use of safety interlocks and automation controls for use with the reject device.

8.2.5.1 Reject Inhibit Photo-Eye

This option connects a photo-eye with a Normally Closed output to the Checkweigher controller's optional #473 or #573 Input #1. The unblocked photo-eye should cause Input #1 to be ON. When a package reaches the rejection point and the Checkweigher is to actuate the reject device, this photo-eye becomes blocked, turning the #1 Input OFF. At this point the Checkweigher controller will actuate the reject output.

Since the Checkweigher does not require photo-eyes to detect the presence of a package crossing the scale, it is possible to manually generate a false weight by pressing on the weigh station conveyor and then releasing. Use of the Reject Inhibit photo-eye at the reject station will not allow the reject device to be actuated unless blocked by a package.

8.2.5.2 Reject Confirmation Photo-eye

This option places a photo-eye at the discharge of the reject device and connects a Normally Open output of the photo-eye to the Checkweigher controller's optional #473 or #573 Input #6. The Checkweigher controller must also be configured to enable this feature. See Chapter 5 "Configuration", Section 5.2.9.7 for information on enabling this option.

When the reject output is generated by the Checkweigher controller, the Reject Confirmation photo-eye must become momentarily blocked within one (1) second of the reject actuation. If the photo-eye is not blocked, an error condition occurs. Outputs #1 through #5 on the #473 or #573 I/O card are turned on and off in one (1) second intervals. A combination of these outputs can be interfaced back to the user's system controls or PLC to receive this error condition. In addition, an error message is displayed on the Checkweigher's screen. This message will remain in place and the outputs will toggle on and off until the operator acknowledges the error by pressing any key on the keyboard.

The Checkweigher will continue to function as normal, weighing packages, gathering statistics, actuating reject signals, etc. even if this error occurs.

8.2.5.3 Reject Lane Full Photo-eye

This option is used in concert with the Reject Confirmation Photo-eye. If the photo-eye is blocked by a rejected package for five (5) seconds or more, it will cause an error condition. Outputs #1 through #5 on the #473 or #573 I/O card are turned on and off in one (1) second intervals. A combination of these outputs can be interfaced back to the user's system controls or PLC to receive this error condition. In addition, an error message is displayed on the Checkweigher's screen. This message will remain in place and the outputs will toggle on and off until the operator clears the photo-eye and acknowledges the error by pressing any key on the keyboard.

The Checkweigher will continue to function as normal, weighing packages, gathering statistics, actuating reject signals, etc. even if this error occurs.

8.2.6 Good Weight Output

Some applications may require an interface from the Checkweigher for rejected packages and “good weight” packages. The Checkweigher controller offers an optional “Good Weight” output that can be used in lieu of attempting to tie the “low pass”, “good”, and “high pass” outputs together. This output is provided on a second #473 or #573 I/O card. The original output card provided with the Checkweigher must be upgraded to or already contain inputs. A second I/O card is added to the card rack, and must contain an address jumper to properly identify this card. See the interconnection diagram at the back of this manual for details on this jumper.

Output #1 on this second I/O card provides the required output. The “good weight” output can be adjusted for length of actuation to accommodate your particular interface needs. See Chapter 4, “Entering Parameters”, Section 4.2.4 for instructions on adjusting this interface.

8.2.7 Early Weight Terminate Photo-Eye Options

The weighing program within the Checkweigher system relies solely upon weigh station load cell information to initiate and terminate the weighment of a package crossing the scale. Typically the leading edge of a package must be approximately 4" off the weigh station conveyor before its weighment cycle is terminated, and before the next package can enter the conveyor.

Certain applications may require the weighment cycle to terminate at or slightly before the leading edge of the package exits the weigh station conveyor. These applications may include; very high production rates, closer than normal package spacing, pop-up reject systems, or Thompson Scale’s own combination Checkweigher/reject system provided on a single conveyor.

There are three (3) optional photo-eye configurations that can be added to the Checkweigher. The first, called EWT1 (Early Weight Terminate 1), uses a single photo-eye mounted at the discharge end of the weigh station conveyor. The second configuration, EWT2, uses a photo-eye at both the entrance and discharge ends of the weigh station conveyor.

The third style, called EWT3, uses photo-eyes at the entrance and discharge of the weigh station conveyor, and an additional photo-eye on the in-feed conveyor before the weigh station conveyor.

PLEASE NOTE: A special configuration step is provided to eliminate false or unreliable operation of these photo-eyes due to reflection from the container/package, or a leading or trailing edge flap. See the configuration menu for use of this feature.

To utilize any of these photo-eye options it is necessary to configure the controller to enable the photo-eye’s input. See **Chapter 5, section 5.2.10**, for instructions on configuration.

Each type of Early Weight Terminate configuration is described below:

The EWT (Early Weight Terminate) options includes the following hardware:

1. Transmit/Receive type of photo-eye (either 110 VAC or 24 VDC)
2. Set(s) of mounting hardware
3. #473 Full I/O card (if 110 VAC) to replace existing 473 ½ card (output only card). This new card adds the required inputs used by the photo-eye

8.2.7.1 Early Weight Terminate Configuration #1 (EWT1)

The EWT1 photo-eye must be placed on the out-feed (discharge) end of the weigh station conveyor, on the centerline of the end roller shaft. The photo-eye should be wired to the Checkweigher controller per instructions found on the interconnection diagram and schematic drawings found at the back of this manual.

When a package enters the weigh station conveyor, weight data is continuously accumulated and stored in the controller's memory. When the EWT1 photo-eye becomes blocked by the leading edge of the package, weight data collection is terminated, and a weight value for that package is calculated. The next package can begin entering the weigh station the instant the 1st package's weight is terminated. Weight data on the 2nd package will be suppressed as long as the EWT1 photo-eye is blocked by the 1st package. Once the EWT1 photo-eye is clear, weight data will be stored in memory.

Minimum spacing requirements on a standard Checkweigher (without the EWT1 option) for packages is typically calculated at the weigh station conveyor's length plus 3" for the Heavy-Duty Checkweigher and about ½" for our Small Package Checkweighers.

Minimum spacing requirements when using the EWT1 option would be to the length of the conveyor only.

8.2.7.1.1 Using EWT1 to Detect Empty Packages

By placing the EWT1 photo-eyes in the proper position, it is possible to detect the presence of an empty package. The Checkweigher begins to detect the presence of a package entering the weigh station based upon a number of factors, including the size of test weight used during calibration. Although it is possible for the Checkweigher to achieve very high accuracies on small weights, it may not be possible for the Checkweigher to initiate a weighment cycle if the incoming package is too light to start the process.

For applications weighing boxes or packages with a height of at least 1", even when empty, the EWT1 photo-eye set (transmitter/receiver) can be placed as described in section 8.2.7.1. However, applications that may dispense an empty package that is effectively flat and has no height need to arrange the photo-eyes slightly differently. The set of eyes should be positioned so that the light beam from the photo-eyes pass from above the conveyor to below the conveyor in the gap between the weigh station conveyor and the next conveyor down-stream.

This beam will be broken by any package, including one that presents a flat profile. It may be necessary to use a particular style or type of photo-eye to provide reliable operation while "looking" through the gap between conveyors. Please consult with the factory for assistance.

8.2.7.2 Early Weight Terminate Configuration #2 (EWT2)

EWT2 uses two sets of photo-eyes to not only terminate the weight of packages, as described above, but can be used to determine if packages are too close together. Some applications may have intermittent problems with product spacing, and occasionally have sets of packages closer than the minimum requirement for the weigh station conveyor. If EWT2 detects this condition, an alarm on-screen is actuated, stating “Product Too Close”, and output #3 on the second #473 or #573 I/O card is actuated.

This alarm output should be used to cause the conveyor system to stop, or allow for a longer than normal reject actuation. A normal reject of these products may cause the second unit to become jammed in the reject device.

8.2.7.3 Early Weight Terminate Configuration #3 (EWT3)

EWT3 uses the two photo-eyes described above in section 8.2.7.2, plus the addition of a photo-eye at the discharge end of the conveyor directly up-stream of the weigh station conveyor. This third photo-eye provides product pacing to the Checkweigher, delivering packages across the weigh station at the highest possible rate for the specific package length.

All photo-eyes connect back to inputs within the Checkweigher controller. Systems with external motor controls, such as our Model 4693i, 4693si & 4693HD checkweighers, generate an output whenever the pacing conveyor needs to stop and hold back the next package. This signal is intended for connection to and interfacing with the user’s motor controls for the pacing conveyor. When the Checkweigher signal goes High (ON), the motor starter for the pacing conveyor must stop. When the signal goes Low (OFF), the motor starter can run.

The conveyor feeding the Checkweigher must be provided with a brake motor to allow for quick stops and starts. This conveyor must be running at the same speed as the Checkweigher conveyor.

The Sonic 350 Small Package Checkweigher operates all of its servo motors internally, and contains the logic and I/O internally to start and stop our own in-feed conveyor before the scale conveyor.

Please reference your system drawings for details on how this feature may be wired into your system.

8.3 Data Collection and Production Reporting Options

The Checkweigher controller can be upgraded to provide one of two types of production analysis and reporting. A third option, found in Appendix B, will print out unit weight listings and a brief summary for each pallet or run but does not include any analysis functionality.

8.3.1 STPR Statistical Production Reporting

The Checkweigher offers an optional statistical analysis and production reporting package for extracting production data from your system. Settings for this package are found under Main Menu item #6, Statistics Data, which is not displayed if the reporting package was not included with your system.

The primary function of the **ST**atistical **P**roduction **R**eport, called STPR for short, is to produce a Production Report which is a statistical analysis of all units weighed in a specific shift, day lot or campaign. In this manual **report** is used to indicate the period of production covered by one production report. There are three basic report types available with STPR. These are:

- Unit Weight Listing
- Interim Report
- Final Report

8.3.1.1 Unit Weight Listings

The Checkweigher Main Menu item #6 Statistics Data, and the main Checkweigher display, offer a choice to turn on or off the unit weight listing. With the STPR dot matrix printer connected and loaded with paper, it transmits a "ready" signal to the Checkweigher controller. If the List feature has been turned "on", each unit weight is transmitted to the printer. Upon the eighth (8th) weight transmission, a carriage return and line feed command is also transmitted.

Eight unit weights print across the page followed by a running total of units produced on this reporting cycle, and an elapsed time since the beginning of the production run. Following is an example of this report. The Checkweigher controller automatically tracks paper position in the printer, and generates a "skip" over the perforation between pages. The Checkweigher also prints the current weight settings and product number as a heading at the top of each page for reference.

Unit Weights will continue to print until the "List" function is toggled off. These listings are useful since they provide a near real-time printout of weights crossing the Checkweigher.

50.19	49.55	49.97	50.05	49.80	50.28	49.83	50.06	108	00:05
49.40>	50.40	49.63	50.05	49.97	49.97	50.25	49.58	116	00:05
50.05	49.99	50.00	50.11	50.22	50.34	50.44	49.55	124	00:06
51.66>	50.17	50.28	51.99>	49.48>	49.30>	50.50	50.01	132	00:06
50.25	50.18	49.75	50.15	49.35>	49.82	50.23	49.84	140	00:07
49.99	49.23>	49.79	50.21	49.50	50.30	49.67	50.31	148	00:07
49.98	49.72	50.20	50.02	49.76	50.32	49.39>	50.23	156	00:07
48.98>	51.41>	48.60>	49.98	49.03>	51.19>	48.55>	49.87	164	00:08
50.05	48.80>	51.28>	48.83>	50.06	49.10>	51.40>	48.63>	172	00:08
50.05	49.97	48.97>	50.25	48.59>	50.05	49.99	50.00	180	00:08
50.11	50.22	50.33	50.44	50.55	50.36	50.17	50.88>	188	00:09
50.19	49.50	49.88	50.50	50.00	50.25	50.18	49.76	196	00:09
50.45	49.55	49.82	50.43	49.84	49.99	49.93	49.79	204	00:10
50.21	49.50	50.43	49.69	50.31	49.98	49.72	50.20	212	00:10
50.12	49.76	50.32	49.39>	50.23	49.98	50.41	49.60	220	00:11
49.98	49.63	50.19	49.55	49.97	50.05	49.80	50.28	228	00:11
49.83	50.06	49.10>	50.40	49.63	50.05	49.97	49.67	236	00:12
50.45	49.59	50.05	49.99	50.00	50.11	50.52>	50.33	244	00:12
50.04	50.15	50.66>	50.07	50.08	50.10	49.50	49.80	252	00:13
50.50	49.90	50.25	50.18	49.75	50.45	49.75	49.83	260	00:13

Report Called 00:13

8.3.1.2 Interim Report

As with the Unit Weight Listing, a prompt is displayed on the Main Menu #6 Statistics Data submenu, or the main Checkweigher display for calling an Interim Report. By calling this report, the display will temporarily display a message that an Interim Report has been called. This report can be called throughout production without interrupting weighments. Multiple Interim reports can be called during production without the loss of data. All data contained in this report is based on weights from the 1st unit up to the last unit to cross the Checkweigher before the report is called. Data is not lost when calling an Interim report. Reports print automatically and contain a heading labeled INTERIM REPORT. A sample of this report is shown on the following page.

8.3.1.3 Final Report

At the end of a lot or campaign, the Final Report is called. This report is identical to the Interim report format, but has two distinct differences. First, the heading at the top of the report is labeled FINAL REPORT. Second, once the report is completed, all data for that reporting period is erased from memory.

Final reports must be called before changing product recipes. When entering the "Enter/Edit Products menu to change from one product set-up to another, a prompt will appear stating that statistical data will be lost if a report is not called before changing product set-up's. Although STPR can hold approximately 65,000 unit weights in memory, it cannot overlap data from two different product types. If this were done, data within a production report would be meaningless.

When the final pieces of data for the Final Report are transmitted to the printer, the Checkweigher controller resets all counters and the elapsed time clock. This clock will not begin running again until the next unit crosses the Checkweigher. If a report is called at the end of a shift, and several hours or days elapse before production begins again, the clock will not start until the first unit crosses the scale.

INTERIM REPORT

COMPILED AND PRINTED BY THOMPSON SCALE 4693 CONTROLLER

FINAL SETTINGS

TARGET WT 37.00 LB
 CONTAINER WT 0.35 LB
 HIGH LIMIT 37.50 LB
 LOW LIMIT 36.50 LB

PRODUCT/LOT NO. Exterior Enamel 1 Gallon
CUSTOMER: Acme Paint Co.
DATE/TIME 02/17/11 08:10:52

SUMMARY OF 2 HR, 01 MIN OF PRODUCTION

	<u>PRODUCED</u>	<u>ACCEPTED</u>	<u>REJECTED</u>	<u>DISCARDED</u>
TOTAL UNITS	1333	917	413	2
TOTAL LB	49303.36	34049.49	15253.87	97.12
UNITS PER MINUTE	11.0	7.58	N/A	
MEAN UNIT LB	36.98	36.98	N/A	N/A
STD DEV. (1 SIGMA)	0.586	N/A	N/A	N/A

+/- 3 SIGMA DISTRIBUTION FOR 1333 UNITS PRODUCED

PERCENT OF TOTAL PRODUCED

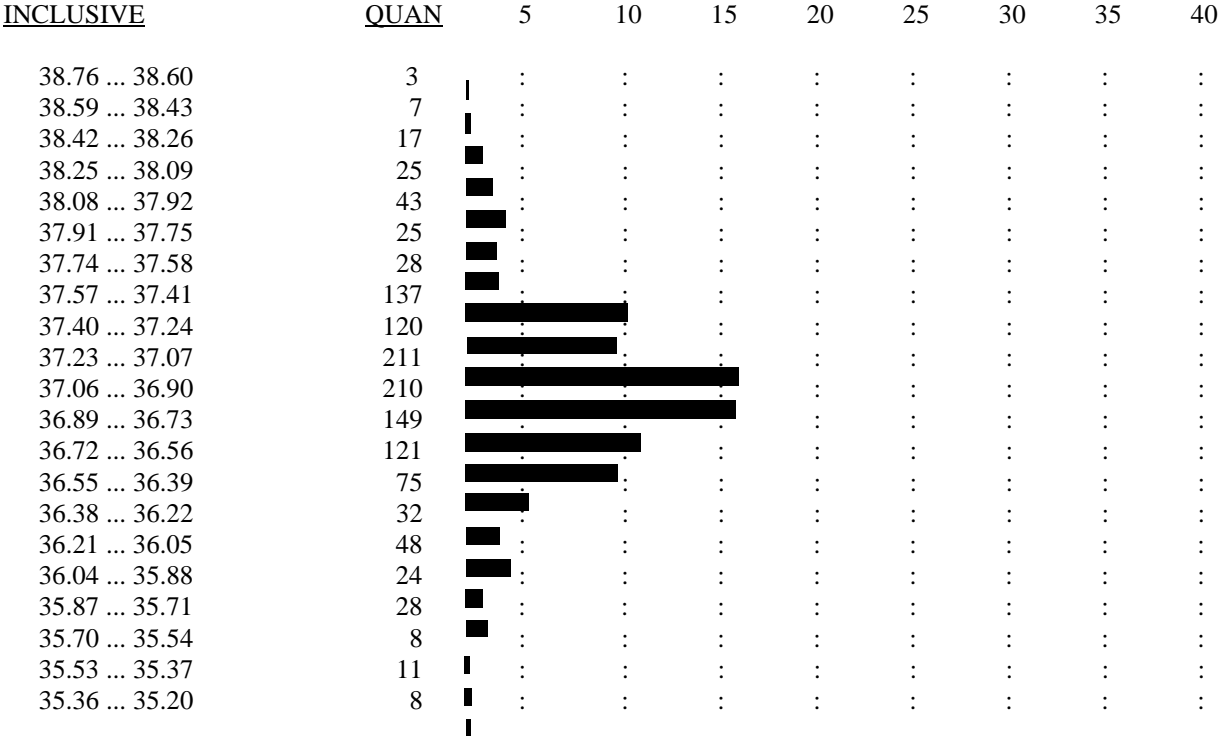

8.3.1.4 Description of Production Reports

8.3.1.4.1 Current Settings

Below the main heading for each report (whether Interim or Final) is a list of settings. When a report is begun (the first unit is weighed), the current settings of all parameters are stored in a separate location in memory. STPR continuously checks these original settings against current settings to detect a change. If the original settings are not changed, then they are printed with the title "Settings". If the original settings are changed, the current settings at the time the report is called are printed with the heading "Final Settings", and a warning message is printed.

"<<<Settings Changed>>>"

8.3.1.4.2 Status Boxes

To the right of the settings block there are three connected boxes containing data for this report. These boxes are: Product/Lot No; Customer; and Date/Time. Each box is automatically filled in from data contained in the product set-up run for this report.

8.3.1.4.3 Summary of Time

This line is located below the current settings and status boxes, and states the number of hours and minutes of production time included in this report. This value is based on the elapsed time at the instant the report was initiated, and is used to determine the number of units per minute in the production data below.

8.3.1.4.4 Summary of Production

Most of the data contained in the summary of production box is self-explanatory. The far left hand box contains the titles of each block of data. Data is broken down into four (4) categories. Total Produced, Total Accepted, Total Rejected and Discards.

The Total Produced category covers all unit weights that occurred during this reporting period, except those that were deemed as "discards". This data includes the total number of units produced, their total combined weight in either pounds, kilograms, ounces or grams as specified in the product set-up, units per minute (total number of units divided by elapsed time), mean unit weight (total weight divided by total units), and Standard Deviation (1 Sigma). Standard Deviation is described in more detail below.

The Accepted category contains the same type of data subjected to the low and high reject limits shown in the current settings block of the report, and typically shows the number of units that passed weight inspection on your production line. Please keep in mind that any rejected units that have been manually trimmed to weight should be passed across the Checkweigher again so their data can be counted as part of accepted production. If this is not done, you may have more units reach your palletizing or unitizing equipment than shown on the reports.

The third category shown in this block is the number of rejects. Only the total number of units and total weight is shown in this category since in most all cases these units are recycled or corrected and passed through the system again.

The final category listed as "Discarded" contains information on unit weights that were not within a range close enough to actual production values to be considered as part of production. That is to say, the weight value was so far away from the normal weight value that it is not included in the statistical analysis.

There are two important reasons for generating a "Discarded" category. First, the statistical analysis of any population relies on the use of valid data. Broken or half-filled units passing across the Checkweigher or multiple units crossing generate weight values that are so far from the norm that they would distort the analysis of normal data within the report. Second, in most all cases, it is important to generate a report with the most useful data possible. The Checkweigher provides a means for the selection of the discard limit based upon your actual production requirements. Main Menu item #6 (shown with STPR option only) contains a submenu for entering a discard percentage ranging from 5% of target weight to 20% of target weight. See Statistics Data Menus below for more information.

8.3.1.4.5 Distribution Graph

Below the summary of production is a bar graph or histogram divided into 21 "zones" showing the total number of units that have occurred in each zone during this report.

The width of each zone is not arbitrarily set. Instead, it is calculated for each report so that the 21 zones cover a range of at least plus and minus 3 Sigma from the mean of the population included in this report. For reports having a very small Standard Deviation, the zone width may be only one unit of resolution (this is the minimum zone width). For reports having a larger Standard Deviation, each zone will expand to contain as many weight values as necessary to meet the plus and minus 3 Sigma requirement.

8.3.1.4.6 Definition of Standard Deviation

Statistical analysis of your production is an important part of your quality assurance program, and can be of great benefit in improving the efficiency of your packaging operation. However, it is important that all terms within this report are understood to make the report meaningful.

Standard Deviation is a mathematical term whose definition loosely translates to "average error". Standard deviation is used to evaluate a population and determine the average error from the mean, or average value. In this report, Standard Deviation describes the calculated average error of product weight from the Target weight. To derive Standard Deviation, all weight values occurring are compared to the Target weight. The difference or error between this value and the Target weight is stored in a table in memory. Once all errors are calculated, each error is squared, and then all values are added together. This number is then divided by the number of values in the table, and the square root of this is calculated. This is the Standard Deviation.

When evaluating a production report, the Standard Deviation will provide information on the overall performance of your packaging equipment. One benefit of Standard Deviations calculations as opposed to just the Mean Unit Weight, is that the squaring and square root functions have a tendency to filter out the extreme high and low errors from the overall population. This provides a more realistic picture of the majority of your production. Since this filtering function takes place, the final number usually contains only about 95 to 97% of the total population.

Between the summary of production boxes and the distribution graph is the statement "+/- 3 Sigma Distribution for "X" Units Produced" Sigma is another mathematical term that means several Standard Deviations. So, 3 Sigma equals the Standard Deviation times 3. In the STPR statistics report, we calculate the 3 Sigma value and generate a plus and minus weight value on each side of the Target weight. In this way the report bar graph contains the majority of weight values occurring during production.

Since Standard Deviation does qualify weight values within the report, some values at the high or low range may not always fall within the 3 Sigma distribution, and may not be included in the bar graph at the bottom of the page. So, the graph may not contain exactly the same number of unit weights as Total Units Produced in the Summary of Production box.

8.3.1.5 Theory of Operation

When the first unit weight crosses the Checkweigher, its value is stored in a register within memory on the #470 CPU card, and is given a counter for the number of times this exact value has occurred. As each weight value is generated by the Checkweigher, its weight is compared to weight values already stored in memory. If the weight value already exists in memory, its associated counter is incremented by one. If the weight value does not exist, a new value is opened in the register and its counter is set to one (1). An additional flag within memory is associated with each weight value to state whether it is an "accepted" or "rejected" weight value.

Values are continuously stored throughout production, and are constantly compared to the product set-up values being run. The List feature can be turned on to simultaneously print each weight value as it occurs, or can be left off and the CPU will continue to store each value. The weight registers and counters described above are used in place of storing each individual unit weight to reduce the overall amount of memory requirements, so it is not possible to generate a unit weight listing for data previously stored.

At the moment a Production Report (Interim or Final) is called, STPR sets an internal flag, and the value list buffer is closed. While the current report is being transmitted, values of units crossing the Checkweigher are stored in a queue or secondary buffer so a report may be called without interrupting production. If a report is called as a lot is finished, and another begins immediately, the unit weights from the new lot will be queued until the report is completed. Upon completion those values are taken out of the queue in the same order that they occurred, and STPR treats each as if it had just occurred. (There is a very slight distortion of elapsed time on the first listing line or two, because STPR always prints current elapsed time, and transmission of the report may have taken one or two minutes to complete.)

If the printer is inadvertently set "Off-Line" due to paper out or loss of power during transmission of a report, STPR will terminate the report transmission, but will not clear memory on a Final Report. It will then add the queued values to those previously collected. The elapsed time counter will not be reset.

Keep in mind that the printer contains a buffer and may have received all data before going "Off-Line". Do not turn the printer off. Reload paper or correct the current problem and turn the printer back "On-Line". The remainder of the report should complete printing.

8.3.1.6 Optional Remote Report Switch

As an option, STPR can be provided with a remote report switch that enables the operator to call for a report at the printer's location and without going to the Checkweigher controller. This switch consists of a two-position selector switch labeled "LIST ON/OFF - REPORT". The List On/Off switch is used to toggle the unit weight listings on and off, and the Report position is used to call for Interim and Final reports. Calling Interim reports is done by holding the switch to the Report position for less than three (3) seconds. Calling a Final Report is accomplished by actuating the switch in the Report position for more than three (3) seconds. Reports and listings can also be controlled from the Checkweigher front panel.

8.3.1.7 What's Included with STPR

The STPR option can be purchased as part of your new Checkweigher system, or added at any time after installation. The package consists of a software enabled PROM (Program Read Only Memory) chip which resides on the #470 CPU card, and an Okidata or other Dot Matrix Printer (Epson emulation) that accepts standard 9-1/2 x 11 tractor feed paper, and a printer interface enclosure.

The software for STPR is added as a sub-routine to the standard Checkweigher program, and is only available through the factory. PROM's are programmed depending upon options purchased, and can be easily changed if the STPR or other option is purchased after the initial installation. By removing the #470 card from the controller's card rack, you will see a 32 pin I.C. chip slightly to the left of center on the card. This I.C. chip is covered with a label containing information on the model number and current version.

Using a small blade screwdriver or pocket knife, gently pry this chip from its carrier, being careful to get between the carrier and the chip. Prying from one end and then the other, remove the chip from its carrier and set aside. Examine the updated I.C. chip to ensure that the legs are straight, and align the legs with the pin sockets of the carrier. The small notch at the end of the chip must be facing towards the face plate of the card.

Once the STPR upgrade chip has been installed into the #470 card, replace the card in the rack and tighten the thumb screws to secure the card. Upon power up of the Checkweigher controller, you will notice that Main Menu item #6 is now available and ready for configuration.

The printer provided with your STPR package is an Okidata dot matrix printer, and has been pre-configured for use with STPR. This printer has two (2) connectors on the rear of the printer; one for the DB-25 connector on the printer interface enclosure, and another for a standard "Centronics" parallel cable. This second connector is not used.

The printer is not designed for use in production environments and should be placed in an office or storage room that is free from dust or other contaminants. Place the printer on a desk or table with paper feeding from the rear and a clear space for collection of printed paper exiting from the printer. All STPR packages include the printer manufacturer's operation and troubleshooting guide, so please review before operating printer.

The final component of this package is the printer interface enclosure. This Nema 1 enclosure measures 10" x 8" x 4" deep and houses a small terminal strip and 20mA to RS-232C converter board. STPR firmware upgrade, resident in the Checkweigher controller, transmits data to the printer via a 20mA current loop serial port (digital data not to be confused with the 4-20mA analog signals used with process equipment). This is done to facilitate long cable runs to the printer's location. It is possible to run the STPR transmission lines up to 1/4 mile to the printer as long as the cable is constructed of a minimum 18 ga. four (4) conductor cable (seven conductor if using the remote report option described above), and should be run in a dedicated conduit to the printer interface enclosure.

The interconnection diagram provided at the back of this manual describes connection of this cable to the interface enclosure. A pre-wired DB-25 connector is also included and is ready to plug into the rear of the printer. A 110 VAC power cord has also been pre-wired and is required to power the interface board.

The printer interface enclosure should be placed within six (6) feet of the printer.

For troubleshooting purposes, the following chart describes the connections within the DB-25 connector.

Interface terminals	DB-25 connections
TB2-1	Pin 3
TB2-2	Pin 20
TB2-3	Pin 7

8.3.1.8 Statistics Data Menu

With the STPR statistical analysis and production reporting package activated in your system, Main Menu item #6 will appear. This menu and its submenu selections are listed below. Selecting Main Menu item #6 will produce the following menu.

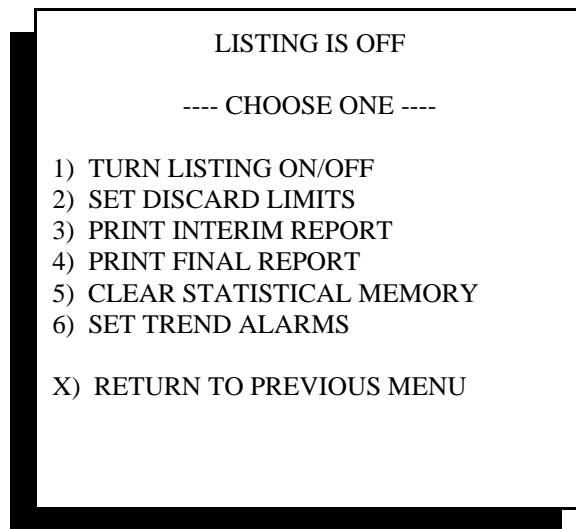

Statistics Data Menu

Selecting submenu item #1 will toggle the STPR listing feature on or off, changing the main heading to reflect the current condition. Listing can also be toggled via the main Checkweigher display and the optional remote report switch.

Submenu item #2 allows for the setting of discard limits as described above in section 8.3.1.4. Selecting item #2 will display the following screen.

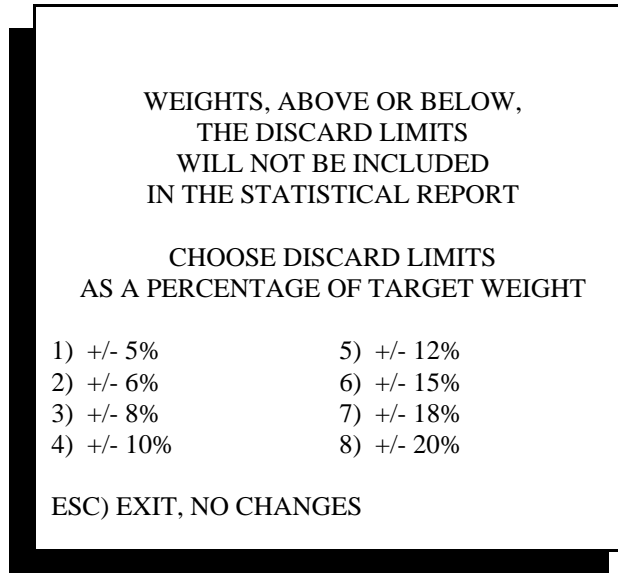

Setting Discard Limits

For a product Target Weight of 50.00 Lbs., a 5% limit would yield a discard at +/- 2.5 Lbs. At 10% the discard limit would be 5.0 Lbs., and at 20% discard limits would be 10 Lbs. This value should be set according to your production tolerances and the amount of "valid" data you wish to include in the Interim and Final Reports.

Items #3 and #4 are used to call for Interim or Final reports from within this menu. This function is also available from the main Checkweigher display and the optional remote report switch.

Menu item #5, Clear Statistical Data is used to clear all data from the reporting registers, and should be used upon start up or other cases where invalid data may reside in memory.

Menu item #6 is used to operate trend alarm features. A "trend" is described as any selected number of consecutive rejects that occur during production. This alarm output can alert the operator to an impending problem with the packaging equipment. To set the parameters associated with this alarm output follow the menu directions.

The trend alarm feature may be turned on or off, and can be set for a specific number of seconds for latching an interface or to run a beacon or alarm horn. Options are provided to set only high or low rejects, or a combination of any type of reject trend. Setting the counts to zero will disable that specific function.

8.3.2 StatPak-PC Data Logging & Reporting Software

As an alternative to the Checkweigher program upgrade printing reports to a dedicated printer, we offer a comprehensive data collection, analysis and reporting software package. StatPak-PC installs in the user's PC and automatically logs each unit weight to an Access database included with the software.

Data is stored by production run. Any completed production run can be quickly called and the data analyzed. Multiple report formats for the data are provided as part of the software. The user can call for a report to display on-screen at the PC or to print at any printer connected to the PC.

Up to 64 independent and unrelated production scales can be connected to StatPak-PC on a single desktop computer. These production scales include in-motion Checkweighers (any brand), net weigh scales, bulk bag fillers, or any type of filling or weighing equipment that operates on a common target weight. These scales need only have a serial output port to connect to the software. Thompson Scale offers a variety of interconnecting hardware devices to facilitate connection of multiple devices. We also offer engineering services to assist with devising the most efficient way of connecting these scales.

The Checkweigher offers programming to allow for seamless connectivity to StatPak-PC. This interface moves storage of product recipe data from the Checkweigher and places all recipes and parameters within the StatPak-PC database. Operators on the factory floor see no real difference in their ability to call or load new product parameters to run, but are now unable to make changes to target weights or reject limits directly from the Checkweigher controller. This provides a significantly higher degree of security for this recipe information.

A Checkweigher controller equipped with program Version 6.0 or higher has the ability to communicate directly with StatPak-PC data collection software. There are two (2) distinct features in the Checkweigher that can be enabled, depending upon the software options and peripheral hardware you have purchased. The two options are product load from StatPak-PC and Down-Time Logging.

8.3.2.1 Communicating with StatPak-PC

An optional bi-directional serial communications port can be added to the Checkweigher controller for use with StatPak-PC. The #477 card is added to the Checkweigher controller's card rack, and is wired as either RS-232 or RS-422 back to the host computer running StatPak-PC. With the card installed, the Checkweigher program automatically recognizes this card, and is ready for use.

To enable this feature, make the following changes to the configuration menu. Access to the configuration menu is done by:

1. Hit Esc on the front panel keyboard until the display shows Main Menu at the top of the screen.
2. Hold down the Shift key on the front panel keyboard, and type EXIT. Upon striking the "T" in EXIT the screen will change over to the configuration menu.
3. Select Configuration Menu item #8, "Get Next Menu". This displays the second screen of the configuration menu.
4. Select Item #8 "Product Load Options"

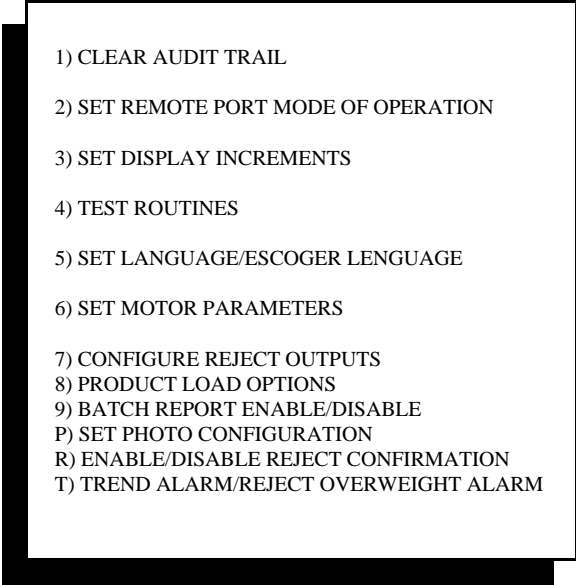

Configuration Menu #2

5. Select Item #2 from this menu:

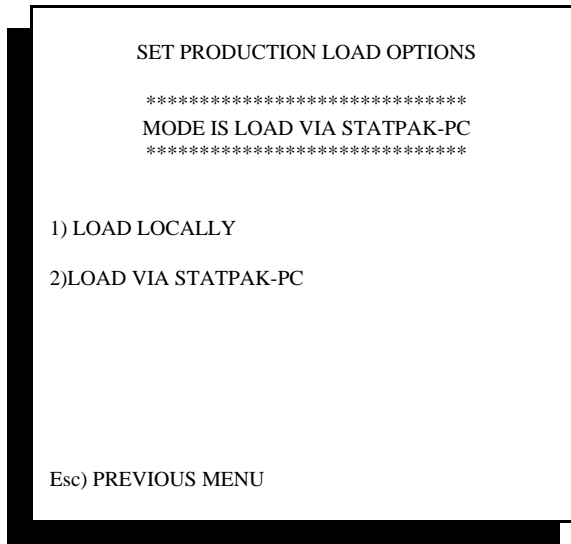

If your application produces packaged material in batches, and each batch is unique and identified by a lot number, time/date stamp, or product code, then select Batch Mode with lot numbers. Each time a new batch is created and/or the operator changes from one product recipe to another, the Checkweigher and StatPak-PC will prompt the operator for entry of a Lot number. Lot numbers are user assigned and not sequential. Values can be any ASCII character set up to 15 total characters (spaces, dashes, etc).

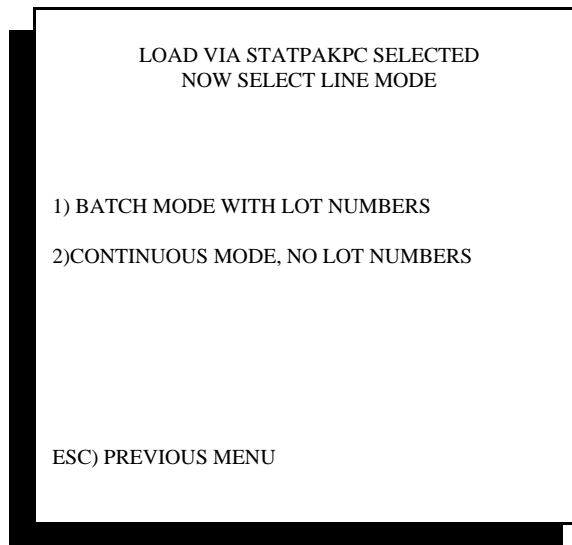

If your application produces the same packaged material on a continuous basis, such as 50 lb bags of plastic pellets, and lot numbers are never assigned to the production runs, then this line would be considered as a continuous production line.

Once a choice has been made, it is not a problem to change from one mode to the other. If this is done, please confirm that the same change has been made within StatPak-PC's line setup.

After a line mode has been selected, hit Esc on the front panel keyboard until the screen displays "Main Menu" at the top of the screen. The controller is now back in its normal mode of operation.

The "Load Via StatPak-PC" selection causes the Checkweigher controller to query the StatPak-PC database for product recipe information, and for entry of material type, lot numbers (if used) and customer name to be associated with a particular product or run. When in this mode, the Checkweigher controller does not retain any product recipe information in memory. When the operator changes from one product recipe to another, the Checkweigher controller sends a request for information to StatPak-PC's database. The closest match is displayed on-screen on the Checkweigher controller, and the operator has the option to select this product, or scroll through other recipes until the correct one is found.

If for some reason communications with StatPak-PC is ever lost, the operator can return to the configuration menu, as shown above, and select "Load Locally". This will return the ability to store and recall product recipe information directly from the Checkweigher's memory.

When running the Checkweigher, the operator will use the "**P**)PRODUCT LOAD" quick key shown at the bottom of the Run Checkweigher screen to change production runs in StatPak-PC. Upon actuating the "P" key, the screen will prompt the operator through selection of several pieces of important production information before loading the proper product to run.

Depending upon your application, the operator may only change production runs when selecting a new customer or new Material to run. However, your application may run the same Material over an extended period of time (weeks, months, etc.), and there will be no real changes to either an associated customer code or Material.

In these cases, the operator will call for a new production run only to segregate information within the StatPak-PC database. You may want information within the database broken into runs based upon either a shift, an operator, a 24 hour day, etc. These specific times can be programmed within StatPak-PC to automatically close the current run and open a new run, or the operator can invoke this manually by pressing “P”, as described above and simply call the same Material again. This will close the current run and open a new run.

When the operator presses the “P” key to load a new product, the screens shown below will appear.

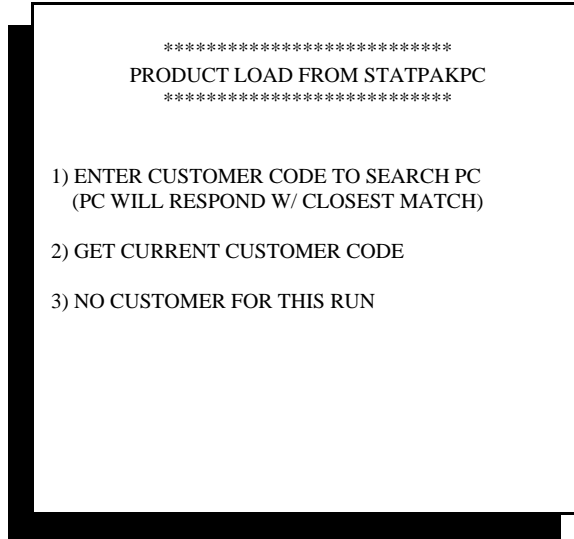

8.3.2.2 Entering Customer Code Information

Selecting item #1 “Enter customer code to search PC” presents the operator with a screen for entering the customer code. The operator can enter the entire code, if known, or can enter only one character. When this data is transmitted to StatPak-PC, the software searches the database to find the closest match, and then presents this information to the operator.

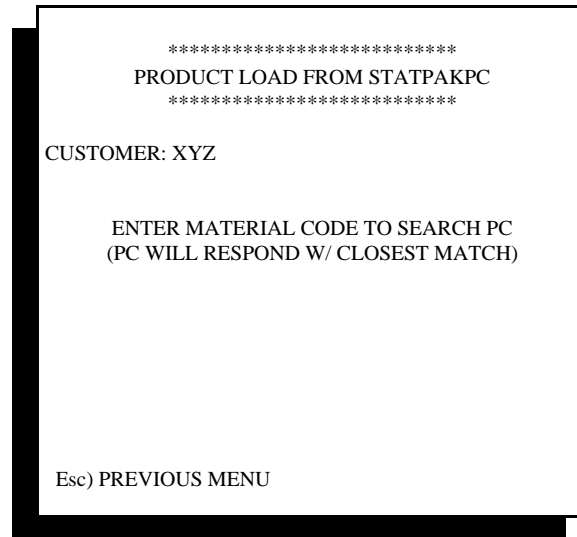

If the operator sees that this is the incorrect information, they can simply hit Esc to return to the previous menu and try again, or continue and will be presented with the opportunity to change the customer code a little later. If the correct customer code information is displayed, the operator can proceed by entering the Material code to associate with this particular customer. Once the Material code is entered, the following screen is presented:

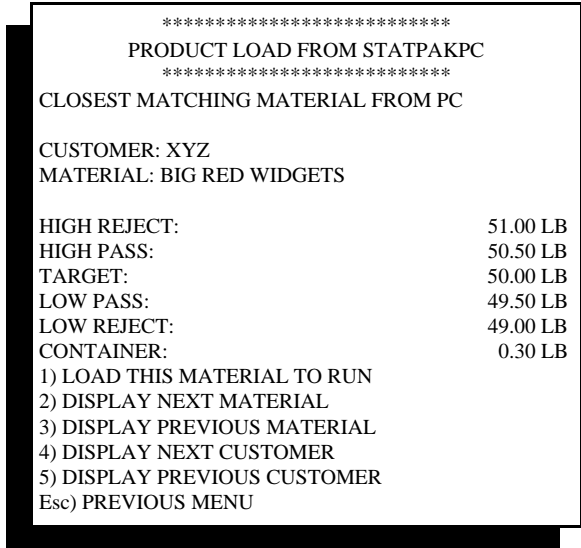

This screen displays the closest matching material code found in StatPak-PC, and presents the code for customer and material, and lists in detail the weight parameters for the selected material. Directly below this information are five (5) options for either accepting and loading this information or displaying either previous or next material or customer codes from StatPak-PC's memory.

8.3.2.3 Getting Current Customer Code Information

As shown in the first screen for calling a new customer/material to run, Menu item choice #2 is “Get Current Customer Code”. Selecting this item will display the current customer code for the production run in progress, and allows this same customer code to be used for the next production run. Selecting this item will lead the operator through all of the above steps, except entering a new customer code.

8.3.2.4 No Customer For This Run

It is quite possible that production runs are not associated with a particular customer, such as running material for inventory purposes. In these cases, the operator would select Menu item #3, “No Customer For This Run”, to start a new production run based upon a new or current material. Selecting item #3 will lead the operator through all of the above steps, except entering a customer code.

8.3.2.5 Lot Number Entry

Once the customer name, if any, is selected the material recipe is then selected. Once the operator accepts the parameters for the material displayed on screen, and the controller is operating in a Batch Mode (see Section 8.3.2.1 above), a prompt will appear for entry of a Lot number. This can be any ASCII value up to 15 characters. Once entered, the operator presses Enter to transmit the lot number to StatPak-PC. This Lot number will now be directly associated with the new production run.

8.3.2.6 Reviewing Current Material Parameters

Once a Material is loaded into the Checkweigher controller, the operator may wish to review this information to confirm that the proper Material and parameters are being used. Main Menu #5 on the Checkweigher controller offers this ability.

Escape from the Run Checkweigher screen to the Main Menu, and select item #5. The following screen will be displayed:

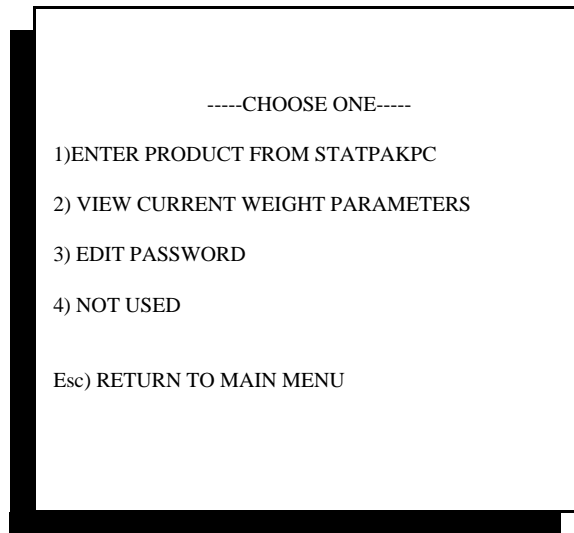

Selecting Item #1 will take the operator to the same screen that is displayed when selecting “P)PRODUCT LOAD” from the Run Checkweigher screen.

Selecting Item #2 will display information on the current weight parameters loaded in memory, as shown below:

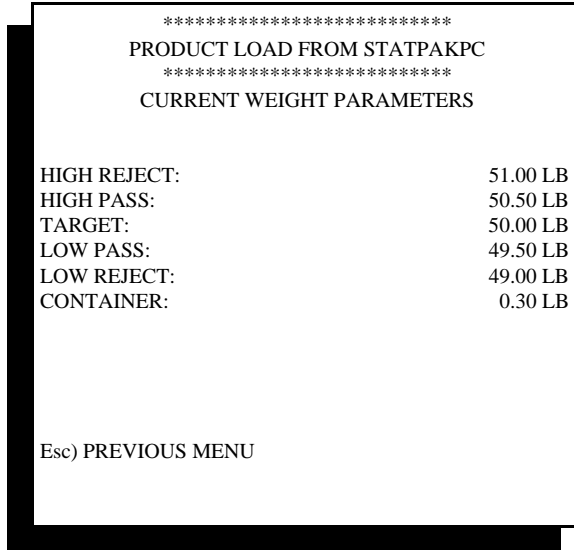

The operator cannot access or change these parameters, only view them. To make changes to weight parameters, the operator must make these changes directly in the StatPak-PC software.

8.3.2.7 Down-Time Logging Assignment

Working in conjunction with StatPak-PC, the Checkweigher controller is capable of logging assignable and non-assignable production down-time occurrences to StatPak-PC’s optional Down-Time reporting Module. If your software contains this option, follow these directions for enabling this feature within the Checkweigher controller:

As described above, enter in to the Checkweigher’s configuration menu. The initial screen displayed offers item #8 to get the next menu. This brings up a second configuration menu screen. Enter into menu item #2, “Set remote port mode of operation”. The following screen will be displayed:

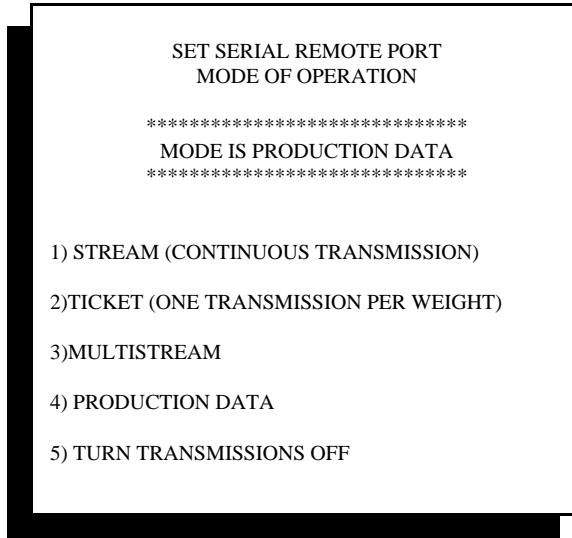

Select item #4 “Production Data”. This enables the down-time logging feature, and performs two (2) functions.

The first function is transmission of production data from the REMOTE port on the #470 CPU card. This data includes three (3) items; Percentage of Down-Time, Units Per Hour, and Total Units. Thompson Scale offers a special three-tier remote display to annunciate this data for operator or supervisory use. These displays are available in either 1” or 2” high 6-digit displays, with three modules housed in a NEMA 4 enclosure.

The second function presents a new Quick-key function on the Run screen, as shown below:

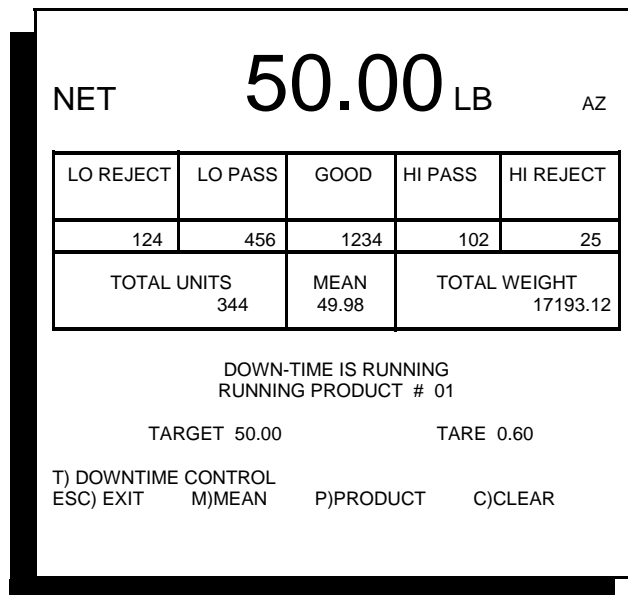

Checkweigh Mode Display

The letter “T” appears above the Esc prompt at the bottom of the screen. Actuating this key will bring the operator to a screen containing information on setting and using the down-time feature.

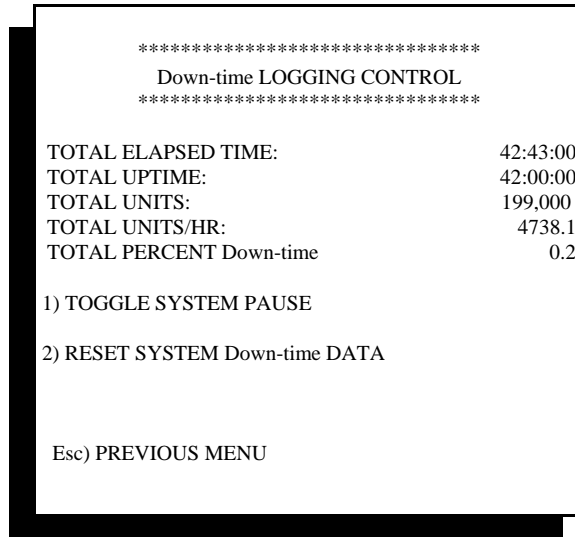

This screen displays useful information about current production time, units, and percentage of down-time. If for some assignable reason, the operator can select Item #1 “Toggle System Pause” to place a hold on production time. Assignable reasons may include shift change, scheduled breaks, scheduled maintenance or cleaning. Supervisors should devise a list of assignable down-time reasons and distribute amongst the operators so that all are clear on reasons for pausing production.

All other reasons for down-time are considered as unscheduled and unanticipated stoppages of production, such as running out of material, broken machinery, etc.

8.3.2.7.1 Elapsed Time

Total Elapsed Time is limited to 99 hours, 59 minutes, 59 seconds of operation. Once this value is breached (100:00:00), the time will reset to 00:00:00. To keep accurate track of time, it is necessary for the operator to manually reset these values at the appropriate time, such as shift change, every 24 hours, etc.

8.3.2.7.2 Total Up Time

This setting relates to the total amount of true production time, and excludes any down-time.

8.3.2.7.3 Total Units

Total units equals the number of units that have been produced during this session of elapsed time. This value will reset when the operator manually resets these counters.

8.3.2.7.4 Total Units Per Hour

Units per hour provides a broad picture of overall production within the span of one hour’s time. This value is obtained by dividing Total Units by Elapsed Time. If Elapsed Time is less than one (1) hour, the value is extrapolated, and does not become truly accurate until the first full hour of production time has passed.

8.3.2.7.5 Total Percent Down-time

This value is based upon Total Uptime divided by Total Elapsed Time, and is shown as a percentile value.

8.3.2.7.6 Toggle System Pause

The system pause feature is used to temporarily suspend both Total Elapsed Time and Total Uptime counters, and should only be used for Assignable Down-time periods such as scheduled breaks or shift changes. It is not necessary to use this pause feature, but keep in mind that overall production data will be slightly skewed based upon these scheduled down-time events taking place. It is also advantageous to use the pause feature since these periods of time are recorded in StatPak-PC's Down-Time Logging Report as Assignable down-time.

If the operator invokes a system pause and a unit weight is generated by the Checkweigher, this unit weight will override the pause and cause the counters to begin running again. This is done in case an operator accidentally pauses the system while production is still running.

8.3.2.7.7 Setting Down-time Delay

Before using the down-time reporting feature in StatPak-PC, you must set a minimum delay time between unit weights. This time is used as a reference point to determine if the production line has become idle and if down-time should be recorded. To select the proper time to enter for this variable, note the actual time between each unit weight generated by the Checkweigher.

As an example, we will use a production line running 60 units per minute. One unit crosses the scale every one (1) second. If the time function were set to two (2) seconds, any time gap greater than two (2) seconds would invoke the start of a down-time occurrence. Once the next unit crossed the scale the down-time occurrence would be closed and the two second timer would begin counting again. This two second time provides adequate time to compensate for minor variations in production rates, yet provides a relatively high resolution of down-time occurrences.

To set this time function, go to the controller's Main Menu, then select item #4 "Set Time/Date". The following screen will be displayed:

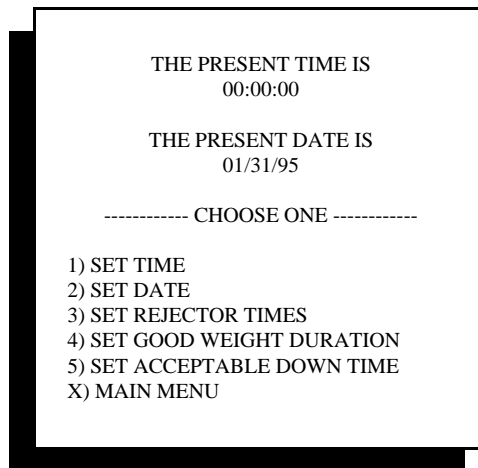

Selecting Item #5 will present the screen shown below. Enter a down-time value in increments of 0.1 second.

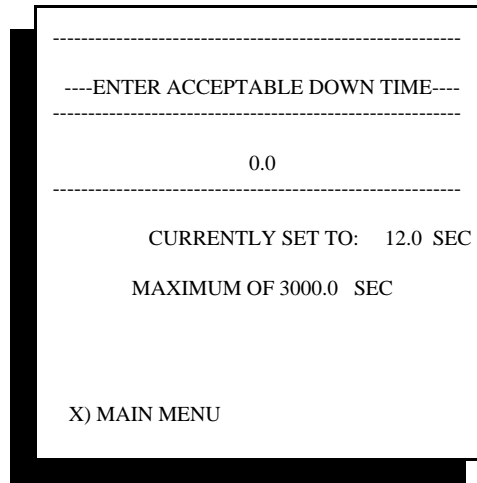

```
-----  
---ENTER ACCEPTABLE DOWN TIME---  
-----  
0.0  
-----  
CURRENTLY SET TO: 12.0 SEC  
MAXIMUM OF 3000.0 SEC  
  
X) MAIN MENU
```

Once the value has been set, hit “X” to return to the previous menu.

With all of these variables set, it should now be possible to create detailed reports within StatPak-PC, showing all occurrences of both assignable and non-assignable down-time. This information will assist the user in determining recurring sources of down-time, and allow monitoring of activity on the production line. Armed with these tools, increases in efficiency and reduction of down-time can be realized.

It will be critically important to enlist the understanding and cooperation of your production staff, making a point to communicate how StatPak-PC and the down-time logging module can make everyone’s job easier, increase productivity without extra effort, and make your production team stand out as a model of efficiency.

More information on StatPak-PC can be found at www.statpak-pc.com

8.3.3 Displayed Production Statistics

The Checkweigher controller is provided with an output only #473 card as part of the factory default configuration. An option is available for upgrading this card to a full input and output card, providing eight (8) 110 VAC inputs. 24 VDC inputs are available as part of the #573 24 VDC I/O card.

Each of these inputs are pre-assigned, as shown below:

#473 or #573 Card #1 (No Address Jumper)

<u>Inputs</u>		<u>Outputs</u>	
1	Reject Inhibit	1	Low Reject Zone Output
2	Metal Detector Reject Input	2	Low Pass Zone Output
3	Remote Statistics Reset	3	Good Weight Zone Output
4	Remote Statistics Pause	4	High Pass Zone Output
5	Remote Statistics "Count" Reset	5	High Reject Zone Output
6	Reject Confirmation Photo-eye/ Reject Full	6	High Reject Timed Output
7	Weigh Station In-Feed Photo-Eye (EWT2)	7	Trend Alarm/Overweight Alarm
8	Weigh Station Out-Feed Photo-Eye (EWT1)	8	All or Low Reject Timed Output

Inputs 3, 4, & 5 can be used in conjunction with remote digital displays, available from Thompson Scale Co.

8.3.3.1 Production Statistics Display

This special display configuration places three (3) 1" or 2" high, 6 digit LED displays into a single enclosure for mounting near an attended production station on the factory floor. Setting the Checkweigher's remote port to the "Production Data" enables the Checkweigher to output a pre-formatted message to the remote displays.

The serial port sends the following data to the remote displays:

Total Units
Units per Hour
Down-time

Total units increment as packages cross the checkweigher.

Units per hour are calculated on total number of packages crossing the checkweigher in 60 minutes, starting with the first unit at the beginning of the production run.

Down-time is configured, as described above in Section 8.3.2.7.7

The 3-tier remote display panel also includes two pushbuttons for managing information shown on the displays. The first button, "Production Data Reset" clears all displayed information to zero. This is used at the beginning of a run or shift to clear for the next run.

The second button, "Production Pause" causes the elapsed timer within the checkweigher to suspend updating the units per hour timer. This is to be used for scheduled production holds, such as shift change or scheduled breaks (lunch, break, dinner, etc.). Pressing the "Production Pause" button a second time will set the elapsed timer back in motion.

8.3.3.2 Remote Statistics “Count” Reset

This feature uses Thompson Scale’s 1" or 2" high 6 digit LED display and a pushbutton connected to Input #5 to provide the operator with a means of tracking the number of packages crossing the checkweigher from a remote location.

At any time, the operator can press the “Count Reset” pushbutton to set the remote display count to zero. As packages cross the Checkweigher, the count increments. This display can be used to allow the operator at a filling station to suspend production once a specific count is reached, or can be used to track the total number of packages completed in a shift or specific time period.

Resetting the remote count does not reset the count or statistics information displayed at the checkweigher.

Chapter 9 Spare Parts

Spare electronic parts offered below are typical for the 4693 checkweigher controls. Other mechanical and electrical spare parts are offered on the drawings found at the back of this manual. Contact Thompson Scale Company, or your local scale service company for additional copies of drawings or spare parts lists.

<u>Part Number</u>	<u>Description</u>	<u>Manufacturer</u>
*470	CPU Card	Thompson Scale
471	Busboard	Thompson Scale
*472	Switching Power Supply Card	Thompson Scale
*200-031	3AG - 1 Amp Glass Fuse for source 110 VAC On 472 Power supply card	Thompson Scale
*200-032	5mm x 20mm 2 Amp Fuse for 5 VDC On 472 Power supply card	Thompson Scale
*200-030	315mA Fuse for + or - 24 VDC On 472 Power supply card	Thompson Scale
*473	110 VAC Full Input/Output Card	Thompson Scale
Alt *573	24VDC Input/Output Card	Thompson Scale
*474	Load Cell Digitizer Card	Thompson Scale
*476	Keyboard Interface Board	Thompson Scale
Alt *477	Dual Port Serial Card (Only used with specific options)	Thompson Scale
484	Ethernet TCP/IP Port	Thompson Scale
200-0243	Optrex LCD Graphics Display Module	Thompson Scale
4693-C110 D/E	Controller Door with Keypad; Fiberglass	Thompson Scale
4693-C111 D/E	Controller Door w/ Keypad; Fiberglass #476 board & display included	Thompson Scale
204-001	CPU to #476 board Ribbon Cable	Thompson Scale

Appendix A

Serial Port Information

The Checkweigher offers several types of serial ports for connection to printers, remote displays, etc. Several other communications ports are available as well, and include Ethernet TCP/IP, Ethernet IP, DeviceNet, Profibus, etc. These are detailed in Appendix E.

The #470 CPU card, contained in every system, provides two (2) serial ports. One labeled "REMOTES" is dedicated to transmitting each unit weight as it occurs. The second port, labeled "PRINTER" is for use with the optional STPR statistical reporting package offered by Thompson Scale. An optional #477 card may be added to the controller to provide full-duplex communications, and is provided in either RS-232 or RS-422 configurations. Each port is described below:

A.1 #470 CPU Card "REMOTE" Port

The #470 CPU card, which resides in the far left slot of the Checkweigher controller, contains an eight (8) pin connector labeled "REMOTES". This 8 pin connector contains two (2) serial ports, both operating on the same protocol and delivering identical data. The port can be hard-wire configured as either a 20mA current loop Active or Passive port. 20mA current loop is a digital signal, not to be confused with a 4-20mA analog signal.

The drawing below, and those shown on drawings in Appendix D, shows the proper wiring for this port.

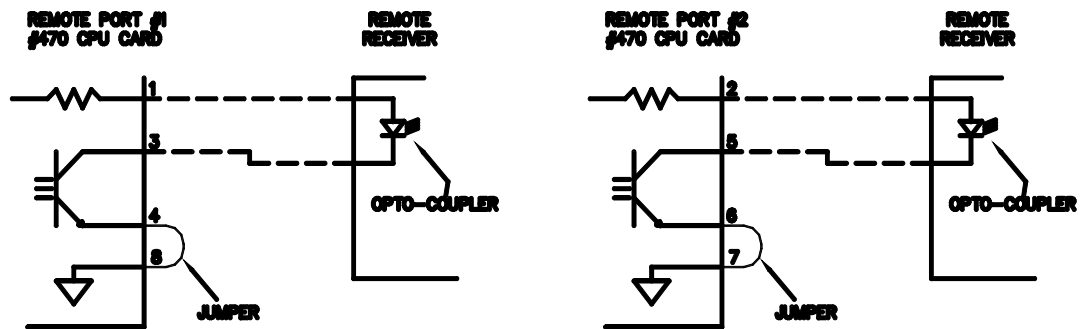

20mA "ACTIVE" CURRENT LOOP CONNECTIONS
Two Ports Available, As Shown

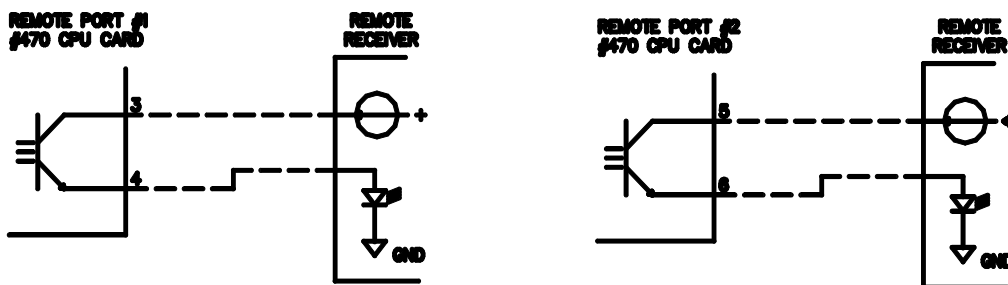

20mA "PASSIVE" CURRENT LOOP CONNECTIONS
Two Ports Available, As Shown

Protocol for the REMOTE port is as follows:

1 Start Bit
 1200 Baud
 8 Data Bits
 No Parity
 1 Stop Bit

Protocol is fixed and cannot be changed.

Data String in either the Ticket or Stream Mode:

<STX><XXX.XX><CR>

Leading Zeros Suppressed

The “REMOTES” port offers no hardware or software hand-shaking, and transmits data as it becomes available. The receiving device is responsible for queuing data.

The “REMOTES” port can be configured to transmit data in either the *Ticket* or *Stream* modes. Ticket mode transmits each unit weight value one (1) time only, and is intended for delivery of data to a line printer or a database or spreadsheet program. The Stream mode transmits the unit weight value continuously until a new weight value is registered by the Checkweigher. The Stream mode is the most common mode used when connecting to a remote digital display.

The default setting for the Checkweigher is the Stream mode. To change this mode, refer to Chapter 5, System Configuration, for further information.

A.2 STPR Statistical Reporting Package “PRINTER” Port

The #470 CPU card, which resides in the far left slot of the Checkweigher controller, contains an eight (8) pin connector labeled "PRINTER". This 8 pin connector contains a single transmitting port with two 20mA current sources (only one is used), and is dedicated to transmission of data from the optional STPR statistical analysis package offered with the Checkweigher as described in Chapter 8 of this manual.

When activated, this printer port transmits data via 20mA current loop (digital signal, not analog). Data from this port is very heavily formatted, delivering detailed reports to the Okidata dot matrix printer supplied with the STPR package. A 20mA current loop port is used since the robust signal is highly immune to ambient line noise, and can transmit up to 1/4 mile without requiring any boost.

The Okidata 320T dot matrix printer, supplied with the STPR package, includes a serial expander card that has been installed in the printer. This card accepts RS-232 serial data.

Between the "PRINTER" port and the Okidata printer resides the #52394 Converter. This device converts the 20mA current loop signal to RS-232, and is provided with a pre-wired connector for the printer. See section A.2.1 below for more information.

Protocol for the PRINTER port is as follows: (data structure is too complex to print here)

- 1 Start Bit
- 1200 Baud
- 8 Data Bits
- No Parity
- 1 Stop Bit

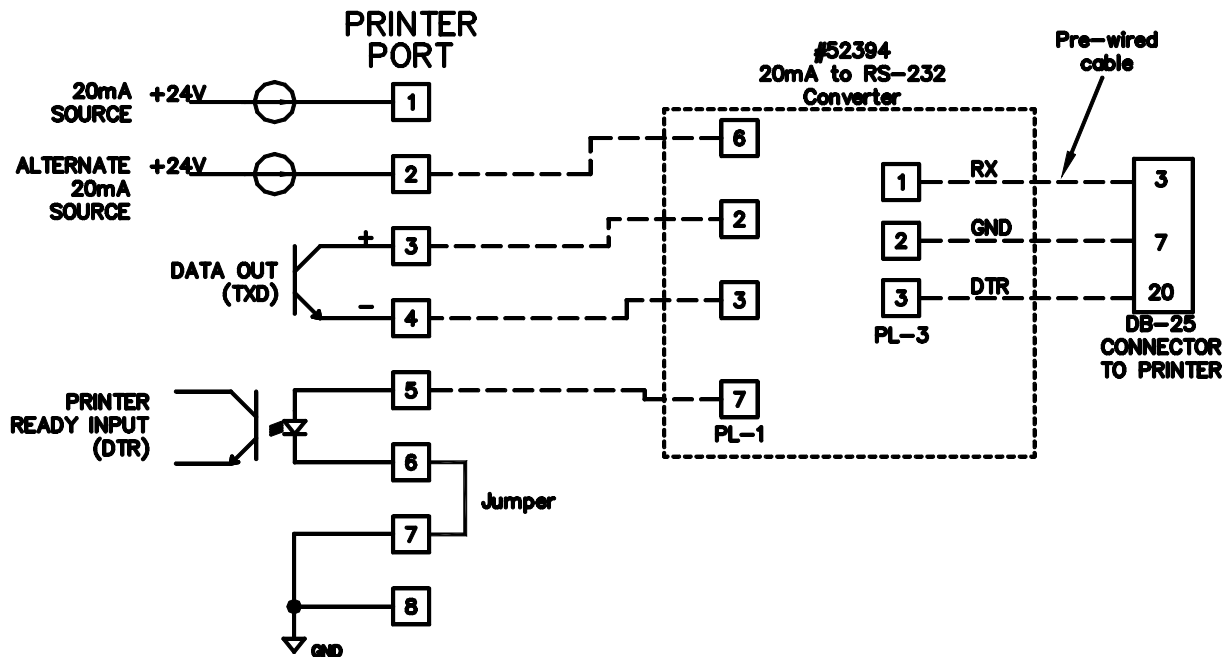

This drawing, and those shown on drawings in Appendix G, show the proper wiring for this port. Information pertaining to the configuration and set up of the Okidata printer can be found at the end of this Chapter.

A.2.1 Serial Converter

The STPR package is provided with a 20mA to RS-232 converter, part number 52394. This converter is housed in a NEMA 1 style painted metal enclosure, and is provided with a pre-wired 110VAC line cord and a communications cable with a DB-25 pin connector for connection to the Okidata printer's serial port. Terminals are provided on the #52394 converter board for connection of wires from the #470 CPU's "PRINTER" port.

The 52394 enclosure is intended for use in an Office Type Environment, and is not suitable for use in a dusty, wet, or corrosive environment. The 52394 enclosure should be placed within five to six feet of the printer, and either mounted to a wall or other structure. Wires from the Checkweigher's "PRINTER" port should be connected, the DB-25 connector plugged into the Okidata printer port, and the Line cord plugged into a GROUNDED receptacle.

Two of the four wires from the Checkweigher's "PRINTER" port are used for transmitting data. The other two are used for PRINTER READY interface between the printer and the transmitting serial port. STPR will not transmit data until the PRINTER READY signal is in the proper state. If the PRINTER READY signal is not in the proper state, and a report is called from the Checkweigher, an error message will be displayed on the controller's front panel alerting the operator to the status of the printer. This occurs if the printer is Off-Line due to power, out of paper condition, or the printer being turned off-line.

LED indicators are located on the converter board, and confirm proper connection of the serial port. When properly connected, the GREEN LED will be on steady state. When data is transmitting, the RED and GREEN LED's will blink alternately. The YELLOW LED indicates that the printer is properly connected and On-Line.

Following are voltage references for the #52394 serial converter board. If the printer is On-Line, has paper, and appears to be operating properly, but there is a problem calling reports, check the following items with a digital volt meter and confirm proper operation of the converter. Please note a plus (+) or minus (-) sign in brackets indicates placement of the positive or negative lead of your meter. Set meter to Volts DC.



WARNING: THIS EQUIPMENT IS TO BE INSTALLED AND SERVICED BY QUALIFIED SERVICE PERSONNEL ONLY.

Instructions within this manual and attached drawings are to be strictly followed to insure both personnel safety and proper operation of the equipment. Please read carefully before attempting to install or operate this equipment.

On 52394 converter board:

PL1 terminal strip. Place meter leads as indicated and note voltages.

- (+)6 & 7 Should produce a +0.7 to +0.8 VDC with printer On
 Should produce a +23 to +24 VDC with printer OFF

- (+)2 & 3 Should produce a +0.7 VDC signal with the Checkweigher controller On
 Should produce a +1.2 to +1.3 VDC signal with controller OFF

- (-)8 & Pin 4 of U1

 Should produce 0 VDC with Checkweigher controller On
 Should produce 4.9 VDC with Checkweigher controller OFF

[NOTE: terminal location #8 does not contain a terminal block. Place meter lead into hole above the location marked 8 on PL1. Locate IC chip labeled U1. This is above and slightly to the left of the PL1 terminal strip. U1 is a six (6) pin device with pin #1 at the upper left corner. Pin #4 is the bottom pin on the right side of the chip]

PL3 terminal strip.

- (-)3 & 2 Should produce +9 VDC with printer On
 Should produce 0 VDC with printer OFF

- (-)3 & 1 Should produce -8 VDC with Checkweigher controller On
 Should produce +7.5 VDC with controller OFF

If you experience a problem with the #52394 board, make the above measurements, and provide actual readings to Thompson Scale via Fax @ (713) 932-9379, Attention Service Department. We will respond within 1 to 2 hours.

A connection diagram can be found on page 133.

A.3 #477 Full-Duplex Serial Card

The #477 card provided with this option is used by Thompson Scale for a number of purposes, including interfacing to packaging machinery, other serial devices, etc. I/O terminals located on this card are not used and should not be connected or jumpered.

As the Checkweigher completes its weighment cycle of a product crossing the scale, the weight value is transmitted out of the serial port on the #477 card. This weight value is constructed of a start character (STX), data characters, weight data and/or commands or error codes, a Carriage Return (CR), and Line Feed (LF). Data can include the weight value only, or a variety of parameters, as detailed in Chapter 5, Section 5.3.4

Protocol, which includes data transmission rates and hardware hand shaking, are fixed per the configuration shown below:

1 Start Bit	Eight (8) Data Bits
No Parity	1 Stop Bit
9600 BPS	

The #477 card can be provided with either RS-232 or RS-422 serial ports. This must be specified at the time of order, and is noted on the face plate of the card. Connections for both are shown below:

RS-232 Connection:

#477 card, pin #2 - Receive
 #477 card, pin #3 - Transmit
 #477 card, pin #5 - Signal Ground

RS-422 Connection:

#477 card, pin #1 Receive +
 #477 card, pin #2 Receive -

#477 card, pin #3 Transmit +
 #477 card, pin #4 Transmit -

#477 card, pin #5 Signal Ground

For further information on connection of this card to your computer, network, or closed-loop system, contact the Technical Service Department at Thompson Scale Co.

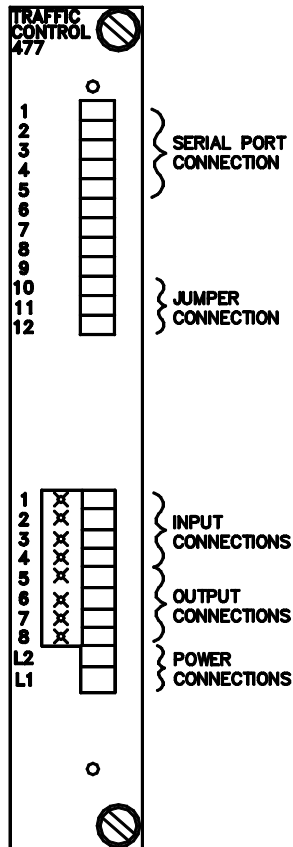

A.4 Okidata Printer Configuration Information

There are occasions where the customer may want to use a printer that is already available to the customer, or a need for the end user to purchase a printer separately from the optional STPR package. Although we strongly recommend purchasing the standard Okidata printer from Thompson Scale as part of a complete STPR package, we offer protocol and configuration information below.

The STPR Interim and Final reports are heavily formatted to provide a pleasing and organized report. Due to this formatting, it is critically important that the printer has the capabilities and features required to handle the text and graphics commands transmitted by the Checkweigher controller.

Some years ago Thompson Scale selected between two distinctly different emulations that were considered standards by the industry. These two types are IBM emulation or Epson emulation. We selected the Epson emulation since it offered a more varied character set. **Any printer connected to the Checkweigher must have Epson emulation.**

Since the vast majority of printers on the market today are provided with only a parallel port, the printer will most likely require an optional serial interface board. This serial interface must be compatible with either 20mA current loop - Active (current source for the port comes from the #470 CPU's port), or RS-232. If RS-232 is used, a serial converter will also be required to accept and convert the 20mA current loop sent from the Thompson controller. Thompson Scale offers a dedicated serial converter for use with our STPR package, which is also available as a separate unit.

The printer must be configured for Epson emulation, and for the following protocol and data formats:

Protocol:

ASCII Data set

1 Start Bit

8 Data Bits

1 Stop Bit

No Parity

1200 Baud

Ready/Busy Protocol

Busy Line = DTR

DSR Inactive

Busy line timeout approx. 200ms

EPSON FX CHARACTER SET EMULATION

Printer Configuration:

No skip over perforation

Auto line feed

No auto carriage return

11" page length

Bi-directional graphics

Draft mode

10 CPI pitch

6 lines per inch

American Character set

Thompson Scale offers consultation and technical assistance free of charge for printers provided by Thompson Scale. We also offer this same service for our customers with other types of printers at a rate of \$35.00 per hour, billed in 1/2 hour increments.

Appendix B

Checkweigher Controller Batch Ticket Print Feature

The Checkweigher contains a standard feature that allows batch ticket printing to an Epson TM-U220 serial printer. The Batch Ticket Mode, when enabled, provides the operator with a means to select the number of “Good” units to include in the batch report, or whether to call for a listing of each unit weight or a summary report for the current batch.

When running a unit listing of each “Good” weight value, the operator can enter a number prior to running production. When that number of “Good” weights cross the scale, a ticket is automatically printed, and includes a Heading with Product name, Customer name, Target Weight, each unit weight, total units, and total weight for that ticket. The Summary report suppresses the listing of each unit weight, but prints all other data fields.

The Batch Ticket Print Feature cannot be enabled if the Checkweigher contains the optional STPR printer package, which occupies the same serial port used by the Batch Ticket Printer. However, the Batch Ticket Feature can be used with data collection software, such as Telemetry Solutions’ StatPak-PC

To enable this feature, the user must enter the controller’s configuration menu. This is done by hitting the front panel Esc key until the controller’s display is in the Main Menu. The words “Main Menu” are printed across the display. Hold down the front panel Shift key, and type the word EXIT. Upon striking the “T” key, the display will change over to the configuration menu.

1) SET SAMPLE RATE	24
2) SET FILTER FREQUENCY	05
3) SET NUMBER OF FILTER SAMPLES	8
4) SET MAX PRODUCT NUMBER	02
5) SET A/D GAIN NUMBER	204
6) SET DECIMAL POINT	02
7) DISPLAY SLOPES	
8) GET NEXT MENU	
Esc) RETURN TO MAIN MENU	

Since there are more configuration items than can be displayed on one screen, the last numbered item on the display is “8 Get Next Menu”. Select number 8 to go to the next screen.

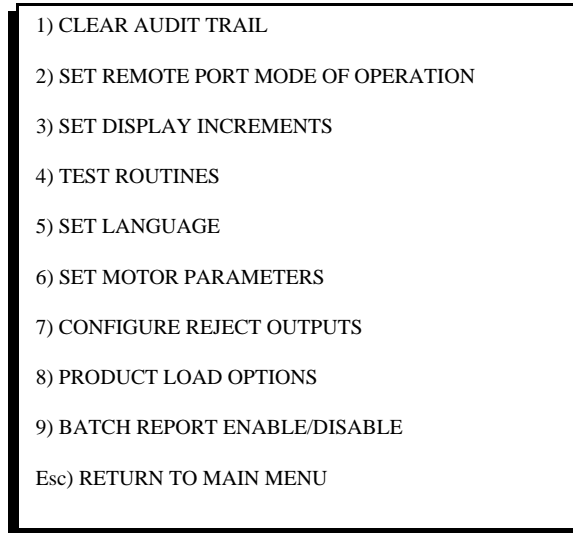

Select Item #9 from this menu “Batch Report Enable/Disable” This will display another screen:

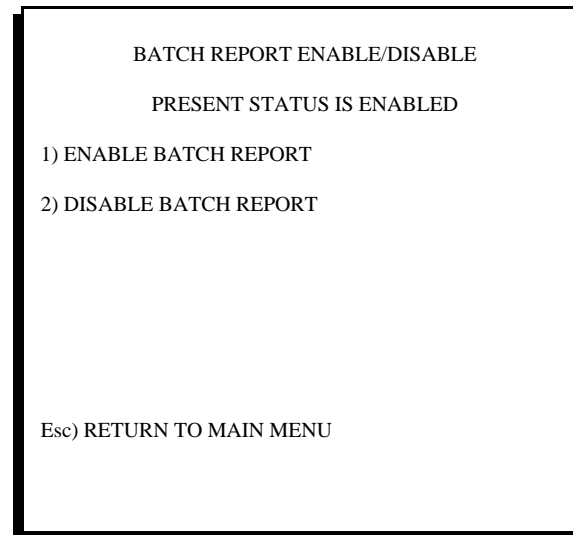

Selecting Item #1 from this menu will enable the Batch Reporting feature.

Once this has been set, hit the Esc key on the controller front panel, until the display again shows “Main Menu”. Selecting item #1 from the Main Menu “Run Checkweigher” will display the operator prompt for setting and using the Batch Report feature.

NET 50.00 LB.				
LOW REJECT	LOW PASS	GOOD	HIGH PASS	HIGH REJECT
123	45	1980	32	16
RUNNING PRODUCT # 28 BIG RED WIDGETS TARGET 50.00 TARE 0.60 T)DOWNTIME CONTROL B)BATCH REPORT ESC) EXIT M)MEAN P)PRODUCT C)CLEAR				

Checkweigh Mode Display

Pressing the letter “B” on the keyboard will invoke a user screen for setting variables for the Batch Report feature, as shown below:

PRESENT STATUS
PRINTER IS ON LINE
PRINT WEIGHMENTS AND SUMMARY
1) ENTER NUMBER OF WEIGHMENTS/BATCH 16
2) PRINT WEIGHMENTS & SUMMARY
3) PRINT SUMMARY ONLY
4) CLEAR BATCH TOTALS
5) PRINT PARTIAL REPORT AND CLEAR TOTALS
ESC)RETURN TO PREVIOUS MENU

Batch Report Menu

This screen first shows the status of the printer. If the printer is on-line, reports can be transmitted and printed. If the printer is off-line, a warning will be displayed on this line.

This top section of the screen also alerts the user to the number of “Good” unit weights that will be included in a batch report. In this example, 16 good units must cross the scale before the report is generated.

Item #1 allows the user to set the number of unit weights to include in the batch report. Minimum value is 1, maximum value is 9,999. If a value of zero (0) is entered, it will turn the batch ticket print function Off.

Item #2 selects printing of each unit weight and the summary

Item #3 turns off the listing of each unit weight and prints the summary only

Item #4 clears all batch totals information for the start of a new batch. This feature makes correction of invalid weights very easy to do.

Item #5 prints out the totals at the time this key is pressed, and overrides the current setting entered into item #1. It does not reset or change item #1, and if left in its current setting, the next batch will include the number of units specified in item #1

Appendix C

Remote Product Load

The remote product load feature is offered as an option to the Model 4693 Checkweigher controller. Remote product load is comprised of a specifically addressed #477 Traffic Control card that enables the use of serial string commands to make changes to settings within the controller.

The transmit port on the #477 Traffic Control card issues an ASCII data string containing possible error and/or acknowledge codes to the host computer system. It is essential that this portion of the port is connected and properly used to ensure proper and safe operation of the checkweigher equipment.

The receive port on the #477 card receives ASCII command strings as set forth later in this document. These strings include commands for changing from one product type to another, modifying product recipe fields, and calling for summary production reports. This port cannot be used for controlling operation of the checkweigher I/O or calibration of the scale.

As an additional option, the serial port, as described herein, may be connected to a protocol converter, such as Ethernet TCP/IP. The data and command structures, as described below, will remain unchanged regardless of the converter used. See Appendix E for more information on Ethernet TCP/IP and EIP converters.

C.1 477 Card Protocol

The #477 card can be provided as RS-232 or RS-422, or may be connected to a serial to Ethernet or other converter. Protocol for the #477 card is fixed at the factory to the settings shown below:

1 Start Bit

No Parity

9600 Baud

Eight (8) Data Bits

1 Stop Bit

C.2 Port Connections

The #477 Traffic Control card serial port can be either a RS-232 or RS-422, depending upon the card specified and purchased. The top connector of this card consists of a twelve (12) pin removable connector.

RS-232 Connection: #477 card, pin #2 - Receive
 #477 card, pin #3 - Transmit
 #477 card, pin #5 - Signal Ground

RS-422 Connection: #477 card, pin #1 Receive + #477 card, pin #3 Transmit +
 #477 card, pin #2 Receive - #477 card, pin #4 Transmit -
 #477 card, pin #5 Signal Ground

For further information on connection of this card to your computer, network, or closed-loop system, contact the Technical Service Department at Thompson Scale Co.

C.3 Product Load Commands

The remote product load option allows for remote operation and product loading of the checkweigher controller. As with manual entry of data into this controller, the remote product load must execute specific steps, in order, to load a new or modify an existing product recipe.

The 4693 controller can store 75 unique product recipes in memory. Remote product load must specify a product number to enter or edit between 01 and 75. Any value outside of this range will invoke an error response from the controller. Any product between 1 and 75 can be loaded in any order desired. If it is desirable to load product #24 before loading #1 through #23, then the controller will automatically create products #1 through 23 to allow access to #24. Since data fields for each product recipe are stored sequentially, it is necessary to open these other product recipes. If no data is entered into these vacant recipes, they will contain no valid data.

Each time a command is transmitted to the 4693 controller a response is issued to either acknowledge acceptance of the data or an error in delivery or receipt of the data. Error codes are shown below. NOTE: "STX", "CR", "LF" & "ETX" represent ASCII control codes, not text.

- E00 (transmitted as "STX E00 CR LF ETX") issued as a data acknowledge command.
- E01 (STX E01 CR LF ETX) issued as a Not Valid Command error
- E02 (STX E02 CR LF ETX) Report Called, No Data In Buffer error
- E03 (STX E03 CR LF ETX) Printer Off Line error
- E04 (STX E04 CR LF ETX) New Product Load Requested, But Data In Statistical Buffer error

The actual data string transmitted does not contain space characters between each data set or command. This has been done in this manual for the sake of clarity.

Product Load Commands are to be in an ASCII format, and are as follows:

- 001 Load Customer Name into Temporary RAM
- 002 Load Product Type into Temporary RAM
- 003 Load High Reject Value into Temporary RAM
- 004 Load High Pass Value into Temporary RAM
- 005 Load Target Weight Value into Temporary RAM
- 006 Load Low Pass Value into Temporary RAM
- 007 Load Low Reject Value into Temporary RAM
- 008 Load Container Weight Value (TARE) into Temporary RAM
- 009 Load Units (described below) Value into Temporary RAM
- 010 Load Values in temporary RAM into Product # "x" (1-75)

****CAUTION! DO NOT ISSUE COMMAND 11. THIS IS RESERVED FOR OTHER USE**

- 012 Load Specific Product Number To Run (1-75)
- 013 Turn Product Listing ON (if STPR option is part of your checkweigher)
- 014 Turn Product Listing OFF (if STPR option is part of your checkweigher)
- 015 Print Interim Summary Report (if STPR option is part of your checkweigher)
- 016 Print Final Summary Report (if STPR option is part of your checkweigher)
- 017 Print Product Recipe Listing (if STPR option is part of your checkweigher)
- 018 Clear all Data in Statistical Buffers (clears statistics and totals displayed in checkweigher "Run" screen, as well as data from STPR buffer)

C.3.1 Entering or Editing A Product

Each product recipe within the 4693 controller contains specific data fields that must be loaded with information before that product recipe number can be called to run as the current product. The current product is defined as the set of product parameters to compare weights across the checkweigher for the current production run. Each product recipe contains a set number of data fields. These fields occur in the specified order shown below:

Customer Name
 Product Type
 High Reject Limit
 High Pass Limit
 Target Weight
 Low Pass Limit
 Low Reject Limit
 Container Weight
 Weight Unit Conversion (lb, kg, g, oz)

Although your specific application may not require information in the customer name or product description fields, these fields must be loaded with at least a SPACE character to insure that the field is cleared of any erroneous data. Therefore, each product recipe set up remotely must be constructed of a series of data strings, each receiving a response or acknowledgment (E00) before the next string or field is transmitted. The customer name and product description fields can contain up to 28 characters. If more than 28 characters are transmitted, an error response will be generated.

Weight data fields, such as High Reject, High Pass, Target Weight, etc. should contain a five (5) digit string without a decimal. This is to say, a weight value of 50.00 should be transmitted as 050000

A typical remote product load would involve sending data as shown below:

Customer Name:	XYZ		
Product Description:	ABC		
High Reject Limit:	51.00		
High Pass Limit:	50.50		
Target Weight:	50.00		
Low Pass Limit:	49.50		
Low Reject Limit:	49.00		
Container Weight:	00.60		
Weight Unit:	*	lbs = 00001	kg = 00002

All data fields are first loaded with information, then Command 010 is used to place this data into a product recipe number. For this example, product recipe #1 is used. Command 012 is then sent to load the current product data to run. As mentioned above, spaces do not exist between each data set, but are shown here for the sake of clarity.

STX 001 XYZ CR LF
response back of E00 from the controller

STX 002 ABC CR LF
response back of E00 from the controller

STX 003 05100 CR LF
response back of E00 from the controller

STX 004 05050 CR LF
response back of E00 from the controller

STX 005 05000 CR LF
response back of E00 from the controller

STX 006 04950 CR LF
response back of E00 from the controller

STX 007 04900 CR LF
response back of E00 from the controller

STX 008 00060 CR LF
response back of E00 from the controller

STX 009 00001 CR LF
response back of E00 from the controller

STX 010 00001 CR LF
response back of E00 from the controller

STX 012 00001 CR LF
response back of E00 from the controller

If Command 012 is issued, and your system has the optional STPR reporting package, it is possible for an error to occur that will state that data is in the buffer and a report must be called or data cleared from the buffer before the new product can be loaded. It is highly recommended that users of the STPR package first call for a Final Report (Command 016) before loading information on a new product and/or attempting to load a new product to run.

STPR users should also write computer software to alert the operator that an error condition exists, such as E003 exists. This may occur even if Command 016 is sent but the printer is off-line or out of paper. If this condition arises, production change-over should not continue since a new product cannot load to run until the printer error is corrected and the Final Report transmitted.

Technical assistance is available free of charge from Thompson Scale Company. Please feel free to call, or send an E-mail from our Web Site; “www.thompsonscales.com”

Appendix D

Tandem 2-Scale In-Line Checkweigher Mode



WARNING: Changing the checkweigher's configuration to this mode will result in improper operation of the checkweigher IF your system is NOT a 2-scale in-line checkweigher. This mode is NOT intended for dual lane (side-by-side) Sonic 350D Checkweighers

D.1 Configuration for Tandem 2-Scale System

The Sonic 350 Checkweigher is by default set to a normal single scale configuration, and must be set up to operate in this special Tandem 2-Scale In-Line mode. Once this mode is configured, the checkweigher's #470 CPU card will retain the configuration, even with power removed for an extended period of time. However, if the CPU card's program is upgraded and/or replaced, it will be necessary to set the configuration as described below:

1. From the Checkweigher's Main Menu screen, hold down the front panel "Shift" key, and type EXIT. Upon striking the "T" in EXIT, the screen will change to a configuration screen, with "Sample Rate" shown as the first item.
2. Select menu item #8 "GET THE NEXT MENU" to bring up the second configuration screen.

```
1) CLEAR AUDIT TRAIL
2) SET REMOTE PORT MODE OF OPERATION
3) SET DISPLAY INCREMENTS
4) TEST ROUTINES
5) SET LANGUAGE/ESCOGER LANGUAGE
6) SET MOTOR PARAMETERS
7) CONFIGURE REJECT OUTPUTS
8) PRODUCT LOAD OPTIONS
9) BATCH REPORT ENABLE/DISABLE
P) SET PHOTO-EYE CONFIGURATION
R) ENABLE/DISABLE REJECT CONFIRMATION
T) TREND ALARM/REJECT OVERWEIGHT ALARM
A) AVERAGING CHECKWEIGHT FUNCTION
F) WEIGHT FEEDBACK FUNCTION
M) SET CHECKWEIGHER MODE OF OPERATION

Esc) RETURN TO MAIN MENU
```

Configuration Menu #2

3. Select item "M) Set Checkweigher Mode Of Operation". The following screen will appear:

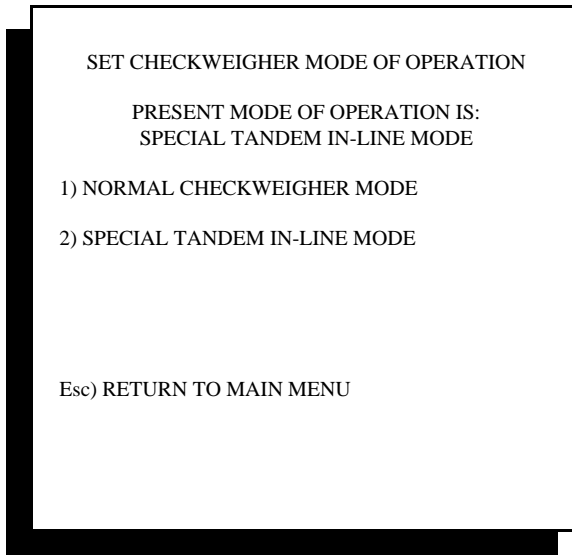

Special Checkweigher Mode

4. Select #2 “Special Tandem In-Line Mode, then press ESC to go back ONE level. This will place you back into the screen shown at the bottom of the preceding page.
5. Select “P) SET PHOTO-EYE CONFIGURATION”. The following screen will be presented:

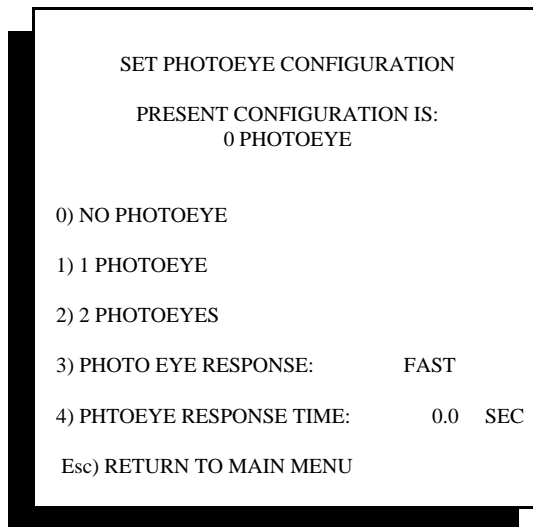

Selecting Optional Photo-Eyes

6. Select #2 “2 Photo-eyes”. This MUST be done to enable the Tandem Checkweigher function to operate properly.

Information on photo-eye response and response time can be found in Chapter 5.

D.2 Tandem Checkweigher User Settings

When the checkweigher has been set to operate as a Tandem In-Line system, changes in several display screens occur. Each is shown below:

D.2.1 Checkweigher Run Screen for Tandem Checkweigher

The checkweigher's Run screen will now display weights for both the first and second scale conveyor, with the rest of the screen displaying normal statistics information.

50.00		50.00		
LOW REJECT	LOW PASS	GOOD	HIGH PASS	HIGH REJECT
123	45	1980	32	16
RUNNING PRODUCT # 28 BIG RED WIDGETS TARGET 50.00 TARE 0.60 T)DOWNTIME CONTROL B)BATCH REPORT ESC) EXIT M)MEAN P)PRODUCT C)CLEAR				

Checkweigh Mode Display

The scale being used to weigh will be active. The other display will be inactive and stay at zero. Totals and other statistics will be updated only for the current scale, and will be cleared when changing from one product recipe to another.

D.2.2 Checkweigher Recipe for Tandem Checkweigher

The product recipe for the Tandem checkweigher includes a prompt to select either scale #1 (up-stream or first scale) or scale #2 to be used for weighing this product recipe. When this recipe is later called by the operator to run that product, only the scale selected within the recipe will be recognized and used for weighing the product.

D.2.3 Checkweigher Reject Times for Tandem Checkweigher

Upon entering in the Main Menu #4 "Set Time, Date & Reject Times", the user will select menu item #3 "Set Reject Times".

Within this menu a choice will be presented to set reject times for scale #1 or scale #2. The Tandem Checkweigher is by default configured to operate a single reject device after both of the scale conveyors. Separate timer sets are provided for each scale, allowing for either a large or small package to be rejected at the proper point by the same reject device.

Appendix E

Ethernet Interfaces

The 4693 Scale controller offers a purchase option for a direct TCP/IP connection, and offers a variety of third-party converters to provide other protocols, such as Ethernet IP (Allen-Bradley), DeviceNet, Profibus, etc.

E.1 Ethernet TCP/IP

The checkweigher can be equipped with a #484 Ethernet TCP/IP (transmission control protocol/internet protocol) card, which includes a standard RJ-45 connection out for connection to the customer's network.

Once the card is installed into the 4693 card rack, power up the controller and connect a network cable to the port on the face of this card. If a connection is being made directly from a PC or laptop computer to the device, please use a network cross-over cable. If the card is plugged into an established network backbone, log onto your PC and access the controller via an Explorer window.

Open an Explorer window on the PC and enter the default IP address shown on the #484 card's label. The following screen will appear:

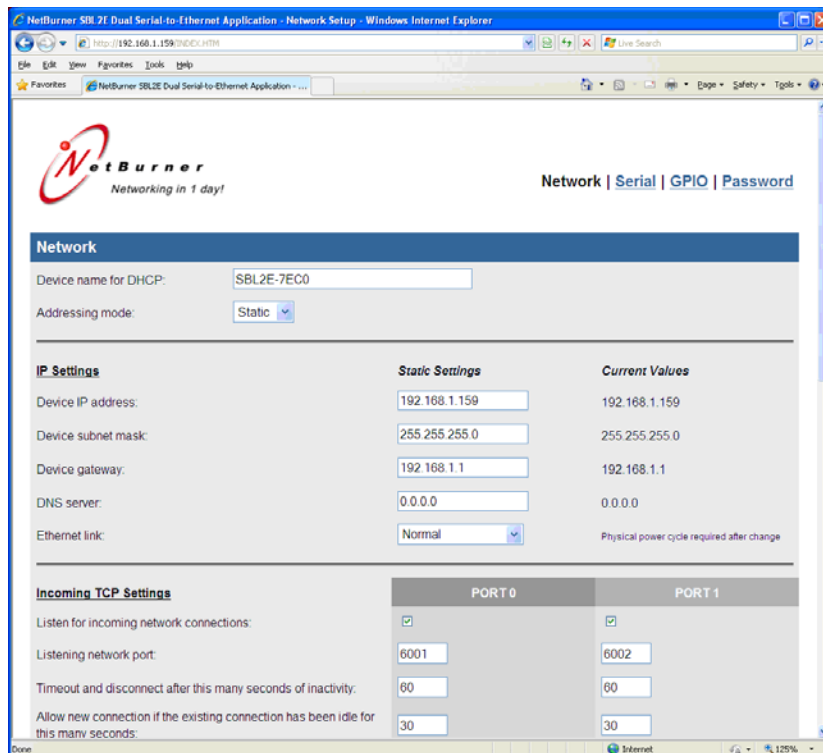

The Device Name and Addressing Mode should remain unchanged.

The Device IP address can be changed to match your network's settings.

Incoming TCP Settings must remain as shown, with Port 0 set to 6001 and Port 1 set to 6002

DO Not change the default settings under the Serial tab

Once changes are made, reboot the 4693 controller and log back onto the network device to confirm your changes.

Data output and exchange are described in Appendix C of this manual

E.2 Ethernet IP Introduction

As an option, the Model 4693 Checkweigher controller, program version 13.0 and higher, offers an upgrade to provide an Allen-Bradley® compatible Ethernet IP (EIP)port with bi-directional communications capability. TSC's part number 51-504-1 consists of:

- #483 bi-directional serial card
- RS-232 to Ethernet IP protocol converter
- 110 VAC to 24 VDC switching power supply to power the protocol converter
- Protocol converter and power supply mounted on DIN rail to back panel of 4693
- Wiring diagram

The #483 card installs into the checkweigher controller card rack, assuming any open position within the rack. A 3-wire communications cable connects to serial PORT 4, at the bottom of this card. This cable runs to the connection port of the EIP converter, per drawings found in the back of this manual. The 24VDC power supply connects to the EIP converter, per these same drawings.

The EIP port transmits every bag weight and other parameters to your network, and in turn can receive commands, including product load recipe commands to change over the checkweigher from one set of recipe parameters to another.

Transmitted and received variables/commands specific to the EIP port are defined on the following pages.

E.2.1 Ethernet IP Communications

All communication with the EIP converter is done through transactions (messages), which must be formatted in a specific manner in order to be properly routed. The EIP converter defines incoming and outgoing transactions (messages) in the following manner:

Variables that are to be transmitted by the 4693 Checkweigher to the EIP converter are called **“consume” transactions** . That is, the EIP converter will “consume” these messages and forward them on to the PLC.

Variables that are to be transmitted by the EIP converter to the 4693 Checkweigher are called **“produce” transactions** . That is, the EIP converter will “produce” these messages as a result of some PLC request or action.

In order to create and define these transactions, the EIP converter is programmed using the Anybus (brand of converter) “ABC Configuration” tool. This is available on CD and via the Anybus website. Once all transactions are created and defined, a configuration file is created and downloaded into the EIP converter. This configuration tool is also used to set the IP address of the EIP converter. This IP address must be changed to match installation site requirements.

To initiate communications between the scale & EIP Converter the checkweigher controller configuration must be changed to enable this feature. Refer to Chapter 5, section 5.3.3

Please reference HMS Ethernet IP configuration files specific to your type of A-B PLC. These files can be found on our CD version of the user’s manual and on our web site at www.thompsonscale.com/support

1. Follow the procedures for configuring your PLC, and set your PLC for 18 bytes for checkweigher output memory and 30 bytes of checkweigher input memory.
2. The PLC should load memory locations for all recipe parameters, as shown below. Be sure to adhere to limits and ranges for these parameters. An error will be issued if any parameter is invalid. Parameters include:

High Reject Weight	Low Reject Weight
High Pass Weight	Container Weight (TARE)
Target Weight	Units
Low Pass Weight	Recipe Number

3. Increment value in memory location of trigger byte. The recipe transfer is initiated by any change in this byte.
4. The PLC should then wait for a response code of recipe transfer. This will be found in the Ack/Nack response byte (see table below)
5. If the transfer has gone successfully, response code 4369 will be issued. Other responses and errors are shown in the table.

E.2.2 Limits and ranges for recipe parameters

In general, all weight variables can be set to any value other than zero. However, in order to operate the checkweigher properly, weights should be set to appropriate and realistic values. This is, High Reject Weight should be greater than High Pass Weight, etc.

Parameter	Value
High Reject Weight	>0
High Pass Weight	>0
Target Weight	>0
Low Pass Weight	>0
Low Reject Weight	>0
Container Weight	0 or Greater
Units	1 = lb, 2 = kg, 4 = oz, 8 = g
Recipe Number	1 through 75 inclusive

E.2.3 Response Codes

Once all recipe parameters have been properly entered in appropriate memory locations, and the trigger byte is incremented, the Ack/Nack byte should be monitored for its response code:

Parameter	Code
Recipe transfer complete	4369
High Reject Weight error	4370
High Pass Weight error	4371
Target Weight error	4372
Low Pass Weight error	4373
Low Reject Weight error	4374
Container Weight error	4375
Units error	4376
Recipe Number error	4377

E.2.4 Input Memory Layout

As mentioned above, there are 30 bytes dedicated to the input of data to the checkweigher:

Address - in HEX	Function
0x200	Trigger byte to initiate recipe transfer
0x201	reserved
0x202	reserved
0x203	reserved
0x204	reserved
0x205	reserved
0x206	reserved
0x207	reserved
0x208	reserved
0x209	reserved
0x20A	High Reject Weight - low byte
0x20B	High Reject Weight - high byte
0x20C	High Pass Weight - low byte
0x20D	High Pass Weight - high byte
0x20E	Target Weight - low byte
0x20F	Target Weight - high byte
0x210	Low Pass Weight - low byte
0x211	Low Pass Weight - high byte
0x212	Low Reject Weight - low byte
0x213	Low Reject Weight - high byte
0x214	Container Weight - low byte
0x215	Container Weight - high byte
0x216	Units/Recipe Number - low byte (recipe number)
0x217	Units/Recipe Number - high byte (units value)
0x218	reserved
0x219	reserved
0x21A	reserved
0x21B	reserved

0x21C	reserved
0x21D	reserved

E.2.5 Output Memory Layout

As mentioned above, there are 18 bytes dedicated to the output of data from the checkweigher:

Address in HEX	Function
0x0000	reserved
0x0001	reserved
0x0002	reserved
0x0003	reserved
0x0004	Final Weight - low byte
0x0005	Final Weight - high byte
0x0006	reserved
0x0007	reserved
0x0008	Ack/Nack Response to Load Command
0x0009	reserved
0x000A	Word = bag count up to 999
0x000B	Word = bag count up to 999
0x000C	Word = 10000 multiplier for bag count
0x000D	Word = 1000 multiplier for bag count
0x000E	reserved
0x000F	reserved
0x0010	reserved
0x0011	reserved

E.2.6 Data Output from EIP

Data output from the EIP port is originally generated through the #483 card included with the EIP kit. Several pieces of data are available and can be configured to meet your application needs. Please refer to Chapter 5, Section 5.3.4 Although this section references the #477 card, which is a different type of serial communications card, the data structure and configuration is the same.

Format is <STX><Scale Letter (A,B,C or D)><Weight>,<Target>,<High Reject>,<Low Reject>,<TARE>,<Date>,<Time>,<Count><CR><LF><ETX>

STX = Start of text ASCII control character

Scale Letter = scale within the controller. The checkweigher controller can have up to 4 scales operating from within one enclosure. If the scale is a single, then the prefix of "A" will be transmitted. If the scale is a dual, then "A" will transmit with weight data from scale #1 and "B" will transmit with scale #2's weight.

Weight = Up to 7 digits + decimal, dependent upon configuration of the controller and maximum weight run on the checkweigher. Leading zeros are suppressed

Target = target weight for the current recipe. As with weight, it may contain a decimal and/or suppressed leading zeros

High Reject = reject limit for the current recipe

Low Reject = reject limit for the current recipe

TARE = container weight, if any for the current recipe

Date = current date format in **mm/dd/yy**

Time = current time formatted in **hh:mm:ss**

Count = incremental count for current production run. Will reset only when recipe is changed or reloaded

CR = Carriage Return ASCII control character

LF = Line Feed ASCII control character

ETX = End of Text ASCII control character

Typical System Drawings

The enclosed drawings are general arrangement and electrical interconnection drawings, and may not reflect the specifics of your particular equipment. Options and accessories shown may not be included with your equipment.

Please contact your reseller or Thompson Scale Company directly for project-specific drawings.

